

FEATURES

- 700 MHz to 40 GHz
- Input Regulators for Improved Stability - Versus Power Supply Variations
- 12 Bit Tuning Resolution
- Compensation for Temperature Drift



DESCRIPTION

MICRO LAMBDA YIG Oscillators, model type, **MLOB, MLXB, MLOS, MLXS and MLXS-T Series** are available with integrated digital driver circuits.

MICRO LAMBDA drivers eliminate the need for customers to design or develop their own driver circuits and sophisticated test and alignment procedures. Integrating a driver at MICRO LAMBDA's factory ensures that peak performance will be achieved at the time of manufacture. Alignment and compensation with the particular YIG oscillator can be maximized down to the component level.

All drivers in this series provide input voltage regulators, and compensation circuits to improve frequency drift.

STANDARD POSITIVE INPUT DIGITAL DRIVER SELECTION GUIDE: PD SERIES

YIG TUNED OSCILLATORS WITH COMMERCIAL DIGITAL DRIVERS

DRIVER INPUT & RESPONSE	SPECIFICATION (0 to + 65 deg. C)
Tuning Command	Start Word (all 0's) = Lowest Frequency Stop Word (all 1's) = Highest Frequency
Tuning Resolution	12 BIT Positive Logic (Fmax-Fmin)/4095 Bit Resolution All Data Bits have Internal 10k ohm Pull-up Resistor to +5V See Table
Frequency Accuracy (excluding hysteresis)	
Tuning Speed	2 mSec for 1 GHz step to within +/-10 MHz.
Main Driver Inputs	
Supply Voltage & Current	+15 V +/- .5 V @ Oscillator Tuning Current + 50 mA, Max. -15 V +/- .5 V @ 50 mA, (Plus Oscillator -5 Vdc Current if any) Max. +/- .5 Vdc , 0.1 MHz Max.
Supply Voltage Pushing	10 mV Ripple Pk-Pk from 2 kHz to 3 MHz
Supply Voltage Ripple	Chassis Ground
Ground	+24 Vdc ±4 Vdc @ 300 mA surge for 2 seconds, 25 mA steady state
YIG Heater Voltage & Current	Polarity independent : ±12 Vdc or ±15 Vdc acceptable
Latch Enable	LATCHEN_N is a TTL, 5V CMOS control line. It has an internal 10k-ohm pull-up resistor to +5 V. It is used to transfer the data on the bus to the digital driver circuit. TTL high = data ignored. Connect to Ground if enable is not required. If the unit is to be used on a computer data bus, the below timing Diagram applies. (All times = Minimum) 10 nS rise/fall latch transitions.

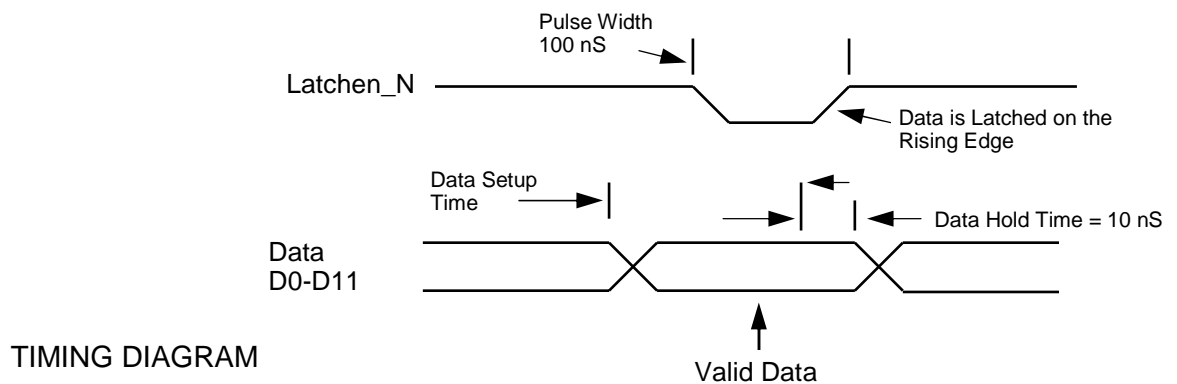

PD SERIES – CONTINUED

FM Coil (PG Option)

Input Voltage	+/- 10V
Input Impedance	1 k Ohms
Sensitivity (Note 1)	+/- 2.5 MHz/V
Frequency Deviation	+/- 25 MHz
Current @ Max. Deviation	+/- 100 mA

Note: 1. Sensitivity Adjustment Available. Sensitivity Stated is Average Over Frequency Range.

1.25" Cube YIG Oscillators with Positive Input Digital Drivers (0° C to +65° C)

Model Number	Frequency GHz	Accuracy (MHz) *	Current +15 V (mA)	Current -15 V (mA)	Outline Drawing	Outline Drawing (PG Option)
Octave Bands						
MLOB-0102PD	1-2	+/- 3	200	50	11-077	11-108
MLOB-0204PD	2-4	+/- 6	300	50	11-077	11-108
MLOB-0408PD	4-8	+/- 8	550	50	11-077	11-108
MLOB-0812PD	8-12.4	+/- 12	780	50	11-077	11-108
MLOB-1218PD	12-18	+/- 14	1050	50	11-077	11-108
Multi-Octave Bands						
MLOB-0702PD	.7-2	+/- 6	250	50	11-077	11-108
MLOB-0704PD	.7-4	+/- 8	350	50	11-077	11-108
MLOB-0306PD	3-6	+/- 6	450	50	11-077	11-108
MLOB-0208PD	2-8	+/- 12	550	50	11-077	11-108
MLOB-0212PD	2-12.4	+/- 15	780	100	11-077	11-108
MLOB-0310PD	3.5-10.5	+/- 15	675	100	11-077	11-108
MLOB-0412PD	4-12.4	+/- 15	780	100	11-077	11-108
MLOB-0716PD	7-16	+/- 18	900	50	11-077	11-108
MLXB-0618PD	6-18	+/- 25	1050	100	11-077	11-108
MLOB-0818PD	8-18	+/- 18	1050	50	11-077	11-108
MLXB-0818PD	8-18	+/- 18	1050	100	11-077	11-108
MLOB-0820PD	8-20	+/- 30	1175	50	11-077	11-108
MLXB-0820PD	8-20	+/- 30	1175	50	11-077	11-108

Cylindrical YIG Oscillators with Positive Input Digital Drivers (0° C to +65° C)

Model Number	Frequency GHz	Accuracy (MHz) *	Current +15 V (mA)	Current -15 V (mA)	Outline Drawing	Outline Drawing (PG Option)
Octave Bands						
MLOS-0102PD	1-2	+/- 3	200	50	11-075	11-131**
MLOS-0204PD	2-4	+/- 6	300	50	11-075	11-131**
MLOS-0408PD	4-8	+/- 8	550	50	11-075	11-131**
MLOS-0812PD	8-12.4	+/- 12	780	50	11-076	11-102**
MLOS-1218PD	12-18	+/- 14	1050	500	11-076	11-102**

* Accuracy includes frequency drift and linearity errors over the temperature range.

** Outline Drawing Available from Factory.

PD SERIES – CONTINUED

Cylindrical YIG Oscillators with Positive Input Digital Drivers (0° C to +65° C)

Model Number	Frequency GHz	Accuracy (MHz) *	Current +15 V (mA)	Current -15 V (mA)	Outline Drawing	Outline Drawing (PG Option)
Multi-Octave Bands						
MLOS-0702PD	.7-2	+/- 6	250	50	11-075	11-131**
MLOS-0704PD	.7-4	+/- 8	350	50	11-075	11-131**
MLOS-0306PD	3-6	+/- 6	450	50	11-075	11-131**
MLOS-0208PD	2-8	+/- 12	550	50	11-075	11-131**
MLOS-0310PD	3.5-10.5	+/- 15	675	100	11-075	11-131**
MLOS-0212PD	2-12.4	+/- 15	780	100	11-075	11-131**
MLOS-0412PD	4-12.4	+/- 15	780	100	11-075	11-131**
MLOS-0716PD	7-16	+/- 18	900	50	11-076	11-102**
MLXS-0618PD	6-18	+/- 25	1050	100	11-076	11-102**
MLOS-0818PD	8-18	+/- 18	1050	50	11-076	11-102**
MLXS-0818PD	8-18	+/- 18	1050	100	11-076	11-102**
MLOS-0820PD	8-20	+/- 30	1175	50	11-076	11-102**
MLXS-0820PD	8-20	+/- 30	1175	50	11-076	11-102**
MLXS-0218PD	2-18	+/- 35	1150	100	11-076	11-102**
MLXS-0218TPD ***	2-18	+/- 35	1150	100	11-068**	11-169**
MLXS-0220PD	2-20	+/- 35	1175	100	11-076	11-102**
MLXS-0220TPD ***	2-20	+/- 35	1175	100	11-068**	11-169**
Millimeter Wave Bands						
MLOS-1826PD	18-26	+/- 30	1200	50	11-146**	11-114**
MLOS-1724PD	17-24	+/- 30	1100	50	11-146**	11-114**
MLOS-1840PD	18-40	+/- 40	1200	50	11-146**	11-114**
MLOS-2040PD	20-40	+/- 40	1200	50	11-146**	11-114**
MLOS-2640PD	26-40	+/- 40	1200	50	11-146**	11-114**

* Accuracy includes frequency drift and linearity errors over the temperature range.

** Outline Drawing Available from Factory.

*** Units are Switched Band units.

Outline Drawing: 11-077

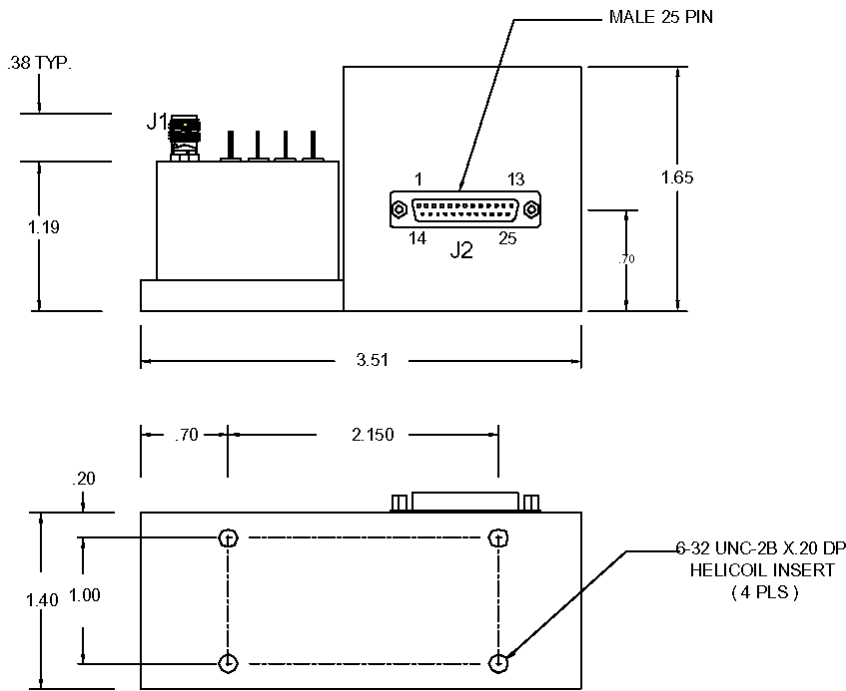

CONNECTIONS			
CONN.	TYPE	PIN #	FUNCTION
J1	SMA	THD	RF OUT
J2	DB25 MALE	1	DATA BIT 0 (LSB)
J2	DB25 MALE	2	DATA BIT 1
J2	DB25 MALE	3	DATA BIT 2
J2	DB25 MALE	4	DATA BIT 3
J2	DB25 MALE	5	DATA BIT 4
J2	DB25 MALE	6	DATA BIT 5
J2	DB25 MALE	7	DATA BIT 6
J2	DB25 MALE	8	DATA BIT 7
J2	DB25 MALE	9	DATA BIT 8
J2	DB25 MALE	10	DATA BIT 9
J2	DB25 MALE	11	DATA BIT 10
J2	DB25 MALE	12	DATA BIT 11 (MSB)
J2	DB25 MALE	13	N/C
J2	DB25 MALE	14	N/C
J2	DB25 MALE	15	N/C
J2	DB25 MALE	16	N/C
J2	DB25 MALE	17	LATCH/STROBE
J2	DB25 MALE	18	GROUND
J2	DB25 MALE	19	+SUPPLY VOLTAGE
J2	DB25 MALE	20	-SUPPLY VOLTAGE
J2	DB25 MALE	21	HEATER VOLTAGE
J2	DB25 MALE	22	HEATER RETURN
J2	DB25 MALE	23	FM COIL +
J2	DB25 MALE	24	FM COIL -
J2	DB25 MALE	25	TTL BAND SELECT *

* REQUIRED FOR DUAL OSC. ONLY

Weight: 16 oz.

NOTES :

- DIMENSIONS ARE IN INCHES
- SUPPLY & GROUND WIRES = 20-22 GAUGE
ALL OTHER WIRES = 24-26 GAUGE
- THERMAL COMPOUND REQUIRED BETWEEN
BASE PLATE AND MOUNTING SURFACE
- LATCH/STROBE TTL 0 = DATA ACTIVE
TTL 1 = DATA LATCHED

Outline Drawing: 11-075 & 11-076

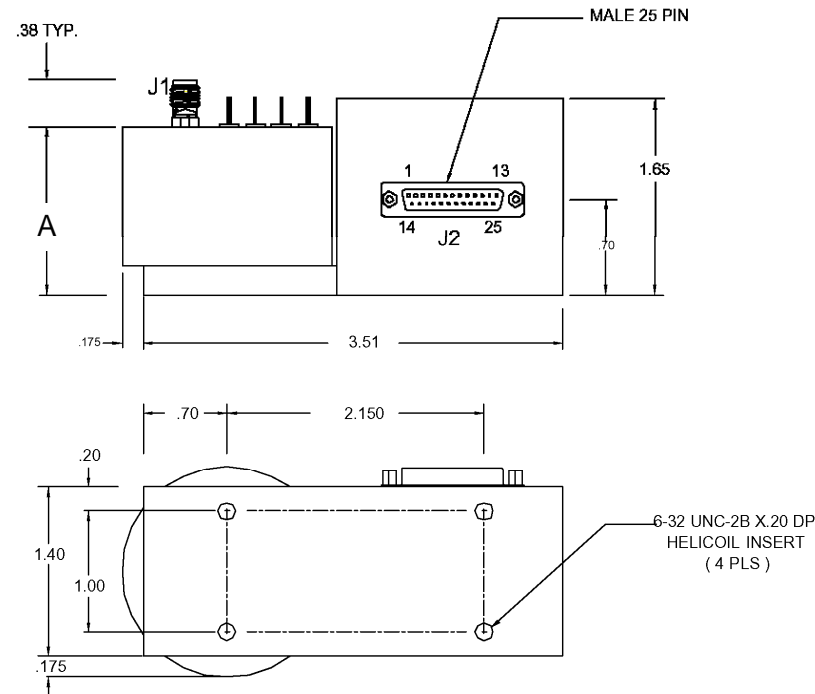

CONNECTIONS			
CONN.	TYPE	PIN #	FUNCTION
J1	SMA	THD	RF OUT
J2	DB25 MALE	1	DATA BIT 0 (LSB)
J2	DB25 MALE	2	DATA BIT 1
J2	DB25 MALE	3	DATA BIT 2
J2	DB25 MALE	4	DATA BIT 3
J2	DB25 MALE	5	DATA BIT 4
J2	DB25 MALE	6	DATA BIT 5
J2	DB25 MALE	7	DATA BIT 6
J2	DB25 MALE	8	DATA BIT 7
J2	DB25 MALE	9	DATA BIT 8
J2	DB25 MALE	10	DATA BIT 9
J2	DB25 MALE	11	DATA BIT 10
J2	DB25 MALE	12	DATA BIT 11 (MSB)
J2	DB25 MALE	13	N/C
J2	DB25 MALE	14	N/C
J2	DB25 MALE	15	N/C
J2	DB25 MALE	16	N/C
J2	DB25 MALE	17	LATCH/STROBE
J2	DB25 MALE	18	GROUND
J2	DB25 MALE	19	+SUPPLY VOLTAGE
J2	DB25 MALE	20	-SUPPLY VOLTAGE
J2	DB25 MALE	21	HEATER VOLTAGE
J2	DB25 MALE	22	HEATER RETURN
J2	DB25 MALE	23	FM COIL +
J2	DB25 MALE	24	FM COIL -
J2	DB25 MALE	25	TTL BAND SELECT *

* REQUIRED FOR DUAL OSC. ONLY

Case	A	Weight
11-075	1.42	16 oz.
11-076	1.65	19 oz.

NOTES :

- DIMENSIONS ARE IN INCHES
- SUPPLY & GROUND WIRES = 20-22 GAUGE
ALL OTHER WIRES = 24-26 GAUGE
- THERMAL COMPOUND REQUIRED BETWEEN
BASE PLATE AND MOUNTING SURFACE
- LATCH/STROBE TTL 0 = DATA ACTIVE
TTL 1 = DATA LATCHED