

## FEATURES

- Superior Phase Noise
- 1 kHz Step Size
- External Reference 1-200 MHz (Optional)
- PXI, Compact PCI Size Compatible
- 5 Line Serial & USB Control

## DESCRIPTION

The **MLSP-Series** of YIG-Based wideband synthesizers are ideal as the main local oscillators in receiving systems, frequency converters and test and measurement equipment. They provide 1 kHz frequency resolution over the 2 to 20 GHz frequency range. Power levels of +13 dBm are provided through out the series and full band tuning speed is 7 mSec. The units are 5" x 3" x 1" high and fit a 2 slot PXI chassis.

## APPLICATIONS

Test Equipment  
Local Oscillators  
Frequency Converters



## PERFORMANCE SPECIFICATIONS

(Operating Case Temperature: 0° to +60° C Baseplate) (Note 1)

Model No.	MLSP-2018	MLSP-2020
<b>RF Specifications</b>		
Output Frequency (Note 2 )	2 - 18 GHz	2 - 20 GHz
Output Power Min.	+10 dBm	+10 dBm
Po Variation over Freq/Temp	6 dB	6 dB
Step Size, Min.	1 kHz	1 kHz
Switching Speed, 100 MHz Step, Typ.	1 mS	1 mS
1000 MHz Step, Typ.	3 mS	3 mS
Full Band Step, Typ.	7 mS	7 mS
Warm-up Time ("Lock") @ 0C (Minutes) (with Internal Crystal Reference)	3.0	3.0
Output Impedance	50 Ohms	50 Ohms
Load VSWR	2.0:1	2.0:1
Harmonics	-12 dBc	-12 dBc
Non-Harmonic Spurious	-60 dBc	-60 dBc
<b>Phase Noise Performance (dBc/Hz)</b>		
(with Internal Crystal Reference)		
@ 100 Hz Offset	-73	-70
@ 1 kHz Offset	-88	-86
@ 10 kHz Offset	-85	-80
@ 100 kHz Offset	-110	-104
@ 1 MHz Offset	-138	-134
@ 10 MHz Offset	-157	-153
@ 100 MHz Offset	-163	-162

## MLSP PERFORMANCE SPECIFICATIONS (Continued)

Model No.	MLSP-2018	MLSP-2020
<b>Reference Oscillator Options</b>		
<b>Option A</b>		
External Reference (Note 3)	1 - 200 MHz	1 - 200 MHz
External Ref. Input Power	0 +/- 3 dBm	0 +/- 3 dBm
Frequency Stability (< +/- 20ppm)	Cust Supplied	Cust Supplied
<b>Option B</b>		
External Reference with Internal Crystal (Note 4)	1 - 100 MHz	1 - 100 MHz
External Ref. Input Power	0 +/- 3 dBm	0 +/- 3 dBm
Frequency Stability (Note 6)	Cust Supplied	Cust Supplied
<b>Option C</b>		
Internal Reference	100 MHz	100 MHz
Frequency Stability	+/- 1 PPM	+/- 1 PPM
<b>Supply Voltage &amp; Current (Note 5)</b>		
+15 Vdc ( $\pm 0.5$ Vdc)	1975 mA	2075 mA
+5 Vdc ( $\pm 0.25$ Vdc)	350 mA	350 mA
Power dissipation	31 watts	33 watts
<b>Supply Voltage Ripple</b> (Pk-Pk from 60 Hz to 3 MHz)	<50 mV	<50 mV
<b>Control Format</b>	5-Line Serial USB	5-Line Serial USB
<b>Phase Lock Alarm (P13) (TTL)</b>	1=Locked	1=Locked
<b>Weight</b>	15 oz / 426 g	15 oz / 426 g

### MLSP Options:

**Option A:** External Reference / No Internal Reference

**Option B:** Internal Reference / External Reference

**Option C:** Internal Reference / No External Reference, Drawing 181-003 & 181-004

**Option D:** RF Connectors Front, Drawing 181-001

**Option E:** RF Connectors Side, Drawing 181-002

Part Number Example: MLSP-2020BD 2 GHz to 20 GHz with Internal Reference and External Reference with RF connectors on front.

#### Notes:

- 1) Special operating temperature range available.
- 2) Special frequency ranges available.
- 3) 50-100 MHz OCXO recommended for best phase noise performance. External reference directly effects phase noise performance.
- 4) Output phase noise performance is not dependent on external reference phase noise.
- 5) All values stated for units with external reference. For internal reference add 125mA on the +15 Vdc line.
- 6) Frequency accuracy must be within exact reference frequency selected, +/- 5ppm.

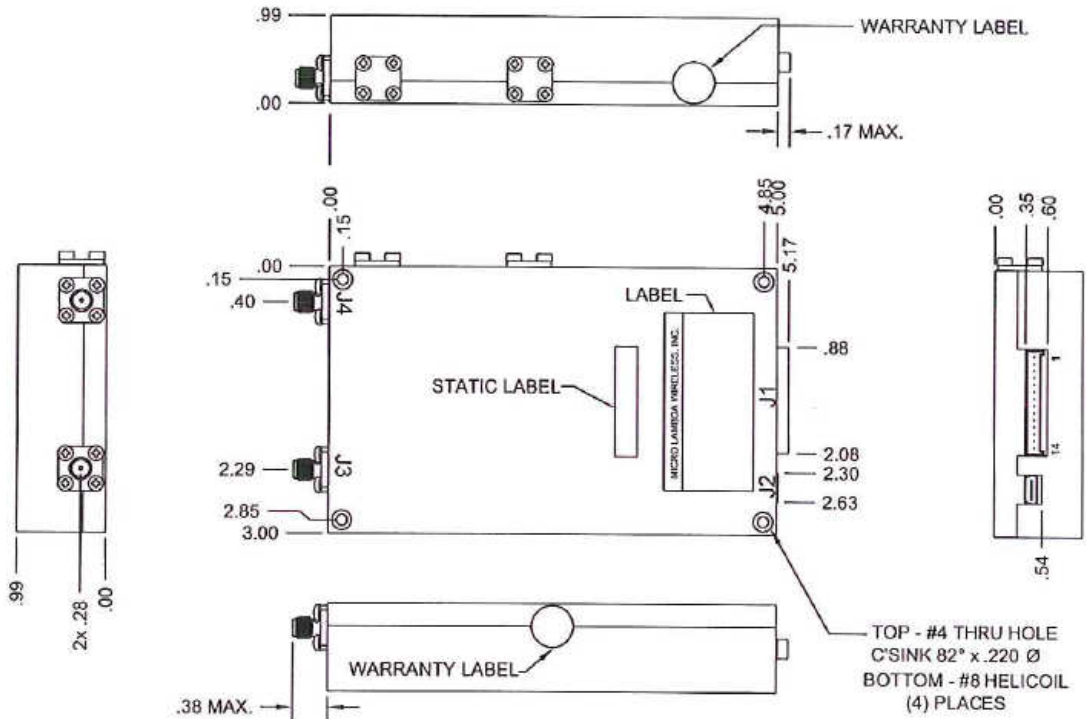

**NOTES :**

- J1 MALE: - MOLEX# 35363-1460
- J1 MATES WITH: - MOLEX# 35507-1400
- CRIMP PIN: - MOLEX# 50212-8000
- J1 POWER SUPPLY INPUTS REQUIRED FOR USB OPERATION
- J1 RECOMMENDED WIRE SIZE = A.W.G. 22-24
- (\*) ACTIVE LOW

CONNECTIONS			
CONN.	TYPE	PIN #	FUNCTION
J1	35363-1460	1	+15 VDC, +12V OPT.
J1	35363-1460	2	+15 VDC, +12V OPT.
J1	35363-1460	3	GROUND
J1	35363-1460	4	GROUND
J1	35363-1460	5	+ 5 VDC
J1	35363-1460	6	+ 5 VDC
J1	35363-1460	7	N/C
J1	35363-1460	8	N/C
J1	35363-1460	9	CLOCK (*)
J1	35363-1460	10	DATA IN
J1	35363-1460	11	SELECT (*)
J1	35363-1460	12	BUSY
J1	35363-1460	13	LOCK ALARM
J1	35363-1460	14	DATA OUT

CONNECTIONS			
CONN.	TYPE	PIN #	FUNCTION
J2	USB MINI-B	1	+V
J2	USB MINI-B	2	D-
J2	USB MINI-B	3	D+
J2	USB MINI-B	4	GND
J2	USB MINI-B	5	GND
J3	SMA-FEMALE	1	REF. INPUT
J4	SMA-FEMALE	1	RF OUTPUT

UNLESS OTHERWISE SPECIFIED DIMENSIONS ARE IN INCHES  
TOLERANCE ARE:  
FRACTIONS DECIMALS ANGLES  
± .01 ± .02 ± .015  
± .005 ± .010 ± .015  
WEIGHT 15 Oz. / 425gr  
FINISH  
DO NOT SCALE DRAWING

CONTRACT NO.	
APPROVALS	DATE
DRAWN N. NGUYEN	3/12/12
ENGR DS	3/12/12
MANUF.	
QA	



MLSP SYNTHESIZER, EXT. REF. ( FRONT )

SIZE	CAGE No	DWG. No	REV.
	ORN63	181 - 001	B

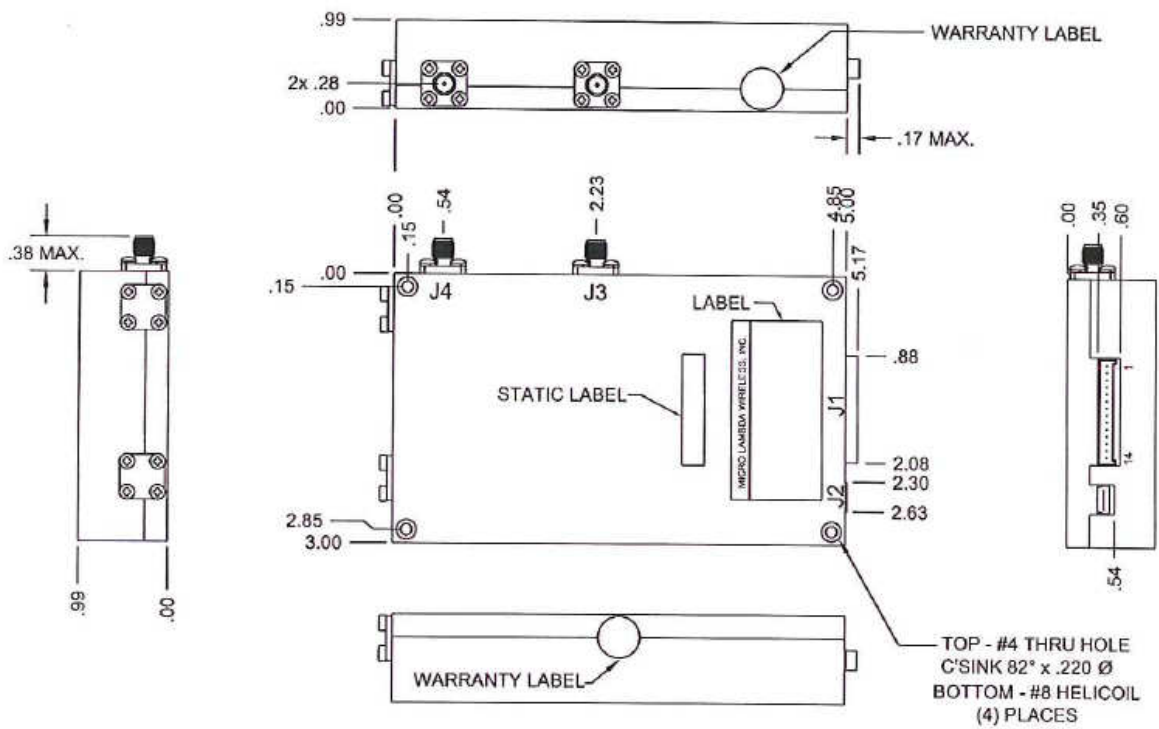

**NOTES :**

- J1 MALE: - MOLEX# 35363-1460
- J1 MATES WITH: - MOLEX# 35507-1400
- CRIMP PIN: - MOLEX# 50212-8000
- J1 POWER SUPPLY INPUTS REQUIRED FOR USB OPERATION
- J1 RECOMMENDED WIRE SIZE = A.W.G. 22-24
- (\*) ACTIVE LOW

CONNECTIONS			
CONN.	TYPE	PIN #	FUNCTION
J1	35363-1460	1	+15 VDC, +12V OPT.
J1	35363-1460	2	+15 VDC, +12V OPT.
J1	35363-1460	3	GROUND
J1	35363-1460	4	GROUND
J1	35363-1460	5	+ 5 VDC
J1	35363-1460	6	+ 5 VDC
J1	35363-1460	7	N/C
J1	35363-1460	8	N/C
J1	35363-1460	9	CLOCK
J1	35363-1460	10	DATA IN
J1	35363-1460	11	SELECT (*)
J1	35363-1460	12	BUSY
J1	35363-1460	13	LOCK ALARM
J1	35363-1460	14	DATA OUT

CONNECTIONS			
CONN.	TYPE	PIN #	FUNCTION
J2	USB MINI-B	1	+V
J2	USB MINI-B	2	D-
J2	USB MINI-B	3	D+
J2	USB MINI-B	4	GND
J2	USB MINI-B	5	GND
J3	SMA-FEMALE	1	REF. INPUT
J4	SMA-FEMALE	1	RF OUTPUT

UNLESS OTHERWISE SPECIFIED DIMENSIONS ARE IN INCHES TOLERANCE ARE FRACTIONS DECIMALS ANGLES  
 \* M + .02 XXX + .010  
 WEIGHT 15 Oz. / 425gr  
 FINISH  
 DO NOT SCALE DRAWING

CONTRACT NO.  
 APPROVALS DATE  
 DRAWN N. NGUYEN 3/12/12  
 ENGR DS 3/12/12  
 MANUF.  
 QA



MLSP SYNTHESIZER, EXT. REF. ( SIDE )

SIZE CAGE No 0RN63 DWG No 181 - 002 REV B