

MICRO LAMBDA WIRELESS, INC.

YIG based Products

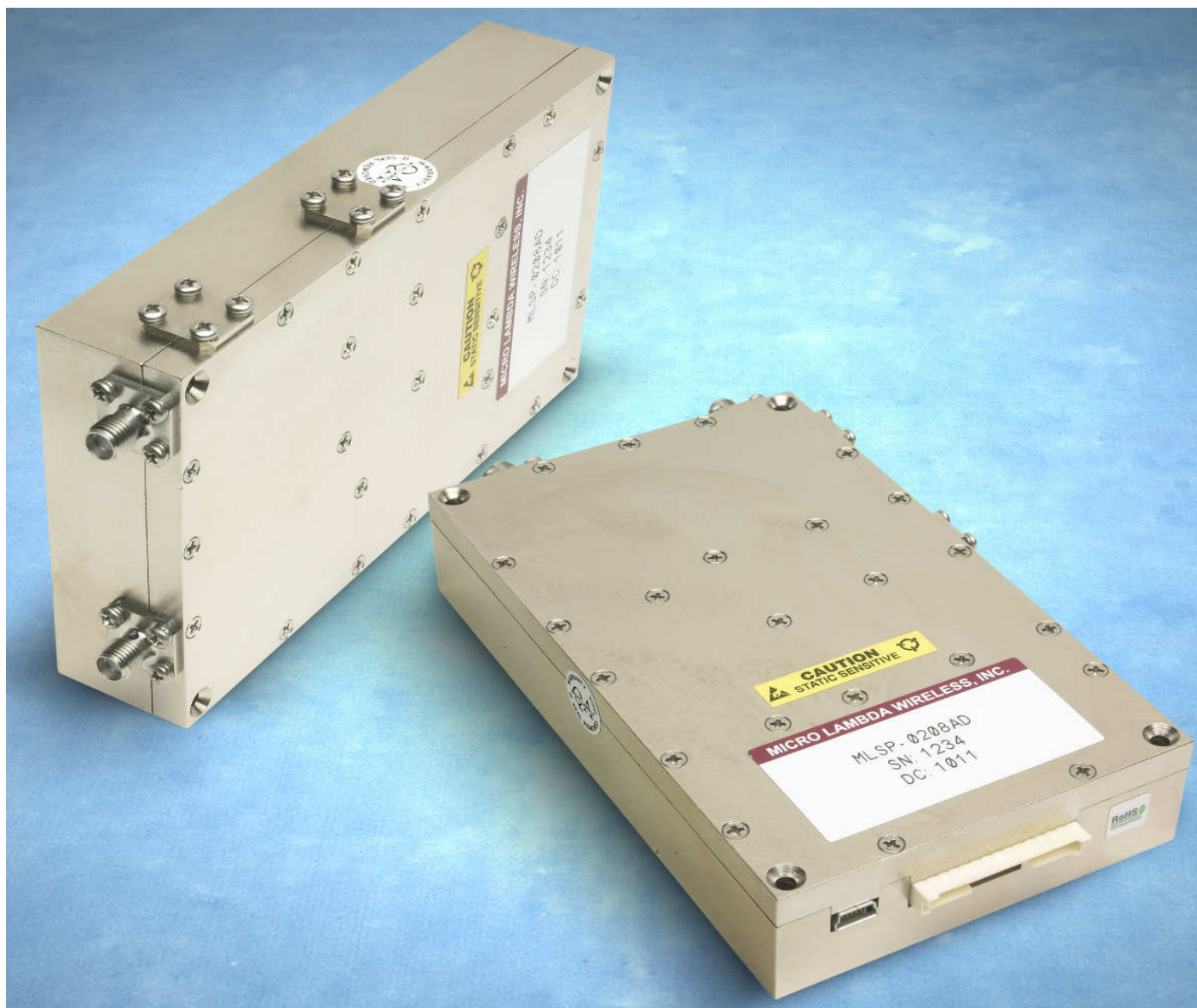

MLSP Synthesizer User Manual

MICRO LAMBDA WIRELESS, INC.

MLSP Synthesizer

User Manual

© Micro Lambda Wireless, Inc.
46515 Landing Pkwy. Fremont, CA 94538
Phone 510.770.9221 • Fax 510.770.9213

Table of Contents

Section	Description	Page
1.0	Introduction	2
2.0	Package contents	2
3.0	General overview of product capabilities	2
4.0	Setup and operation	5
4.1	Connections	5
4.2	MLSP operation	6
5.0	Controlling the MLSP using a personal computer	6
5.1	Installing the documentation and control software	6
5.2	USB interface	6
5.3	USB HID PC interface example, C# source code	8
6.0	Serial interface	9
6.1	Serial interface timing diagram	10
7.0	Communication syntax	11
8.0	Hardware installation information	13
9.0	Technical support	13
10.0	Warranty	13

1.0 Introduction

This manual describes the setup, operation and remote communication for the MLSP Synthesizer. The model and serial numbers are located on the label located on the top cover of the unit. Each unit has a separate, custom specification sheet for the particular model defining the synthesizer's frequency range, RF characteristics and options.

General operating/programming instructions are located herein.

The CD Rom supplied with the package contains a **SetupMLSP.msi** file, when executed, will create a folder named "MLSP Support Files" on the desktop containing short cuts to the manual, documentation and programs for interfacing the product with a personal computer. This **SetupMLSP.msi** file is compatible with Windows XP, Windows Vista and Windows 7. The most current versions of these files, new offerings and standard synthesizer specifications can be downloaded at our web site:

<http://www.microlambdawireless.com>

2.0 Package Contents

Item	Quantity
MLSP Series Synthesizer	Purchased Qty.
DC Power mating connector	Purchased Qty.
USB A male to USB Mini-B cable	Purchased Qty.
CD Rom (Contains manual, quick start guide and PC software)	1 each
MLSP Quick Start Guide (Printed)	1 each

3.0 General Overview of Product Capabilities

The MLSP series of YIG-Based synthesizers can be supplied in wideband or narrowband models and are ideal as the main local oscillators in receiving systems, frequency converters and test and measurement equipment. They provide 1 kHz frequency resolution over the 600 MHz to 20.1 GHz frequency range. Power levels of +8 to +13 dBm are provided throughout the series and full band tuning speed is 3 - 6 mSec. The units are 5" x 3" x 1" high and fit a 2 slot PXI chassis. Standard frequency ranges are 0.6 to 2.5 GHz, 2 to 8 GHz, 6 to 18 GHz and 8 to 20 GHz. The MLSP can be configured with an internal OCXO with a stability of < +/- 1.0 ppm or an external reference signal in the 1 - 200 MHz range. Two types of interface come standard: USB for trouble free connection to a personal computer and a 5 wire serial interface for use in the customers system. Outline drawings 181-001 and 181-002 shown on the next two pages define two of the possible mechanical configurations. These drawings are displayed mainly for the mechanical and the connection information, many other configurations and options are available. See your model specification sheet or contact Micro Lambda Wireless, Inc. for details. Operating temperature ranges outside the 0 to 60 Deg. C range are also available.

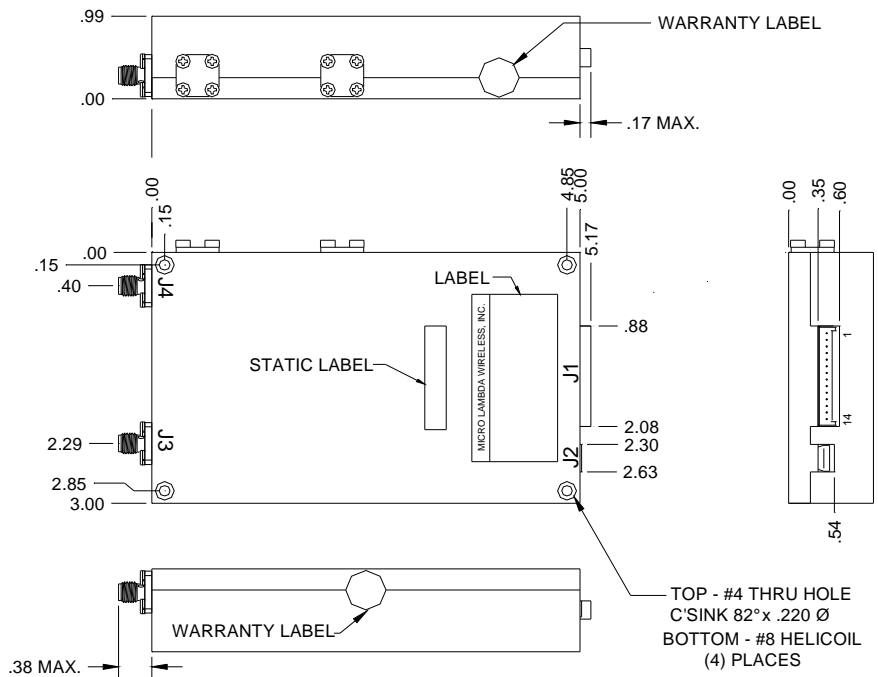

NOTES :

- J1 MALE: - MOLEX# 35363-1460
- J1 MATES WITH: - MOLEX# 35507-1400
- CRIMP PIN: - MOLEX# 50212-8000
- J1 POWER SUPPLY INPUTS REQUIRED FOR USB OPERATION
- J1 RECOMMENDED WIRE SIZE = A.W.G. 22-24
- (*) ACTIVE LOW

CONNECTIONS			
CONN.	TYPE	PIN #	FUNCTION
J1	35363-1460	1	+15 VDC, +12V OPT.
J1	35363-1460	2	+15 VDC, +12V OPT.
J1	35363-1460	3	GROUND
J1	35363-1460	4	GROUND
J1	35363-1460	5	+ 5 VDC
J1	35363-1460	6	+ 5 VDC
J1	35363-1460	7	N/C
J1	35363-1460	8	N/C
J1	35363-1460	9	CLOCK
J1	35363-1460	10	DATA IN
J1	35363-1460	11	SELECT (*)
J1	35363-1460	12	BUSY
J1	35363-1460	13	LOCK ALARM
J1	35363-1460	14	DATA OUT

CONNECTIONS			
CONN.	TYPE	PIN #	FUNCTION
J2	USB MINI-B	1	+V
J2	USB MINI-B	2	D-
J2	USB MINI-B	3	D+
J2	USB MINI-B	4	GND
J2	USB MINI-B	5	GND
J3	SMA-FEMALE	1	REF. INPUT
J4	SMA-FEMALE	1	RF OUTPUT

UNLESS OTHERWISE SPECIFIED DIMENSIONS ARE IN INCHES. TOLERANCE ARE: FRACTIONS DECIMALS ANGLES ± .xx ±.02 ° .xxx ±.010	CONTRACT NO.	
	APPROVALS	DATE
	DRAWN N.NGUYEN	10/03/11
	ENGR.	
WEIGHT	15 Oz. / 425gr	
FINISH	MANUF.	
DO NOT SCALE DRAWING	Q.A.	

MICRO LAMBDA WIRELESS, INC.

MLSP SYNTHESIZER (FRONT)

SIZE	CAGE No ORN63	DWG. NO. 181 - 001	REV. A
------	-------------------------	------------------------------	------------------

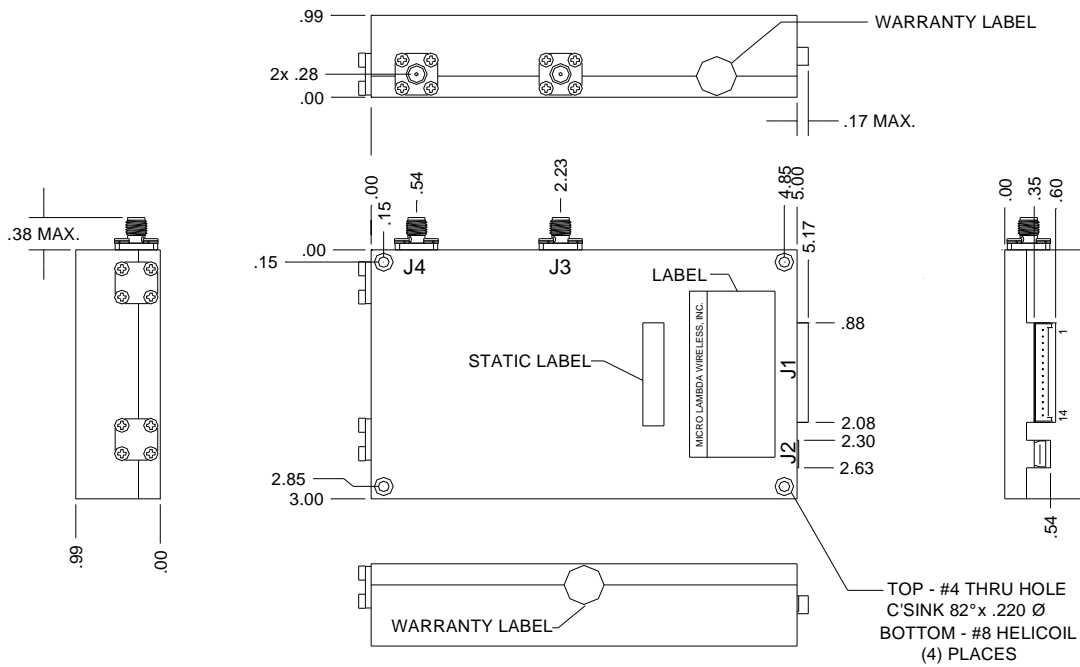

NOTES :

- J1 MALE: - MOLEX# 35363-1460 - J1 POWER SUPPLY INPUTS REQUIRED FOR USB OPERATION
- J1 MATES WITH: - MOLEX# 35507-1400 - J1 RECOMMENDED WIRE SIZE = A.W.G. 22-24
- CRIMP PIN: - MOLEX# 50212-8000 (*) ACTIVE LOW

CONNECTIONS			
CONN.	TYPE	PIN #	FUNCTION
J1	35363-1460	1	+15 VDC, +12V OPT.
J1	35363-1460	2	+15 VDC, +12V OPT.
J1	35363-1460	3	GROUND
J1	35363-1460	4	GROUND
J1	35363-1460	5	+ 5 VDC
J1	35363-1460	6	+ 5 VDC
J1	35363-1460	7	N/C
J1	35363-1460	8	N/C
J1	35363-1460	9	CLOCK
J1	35363-1460	10	DATA IN
J1	35363-1460	11	SELECT (*)
J1	35363-1460	12	BUSY
J1	35363-1460	13	LOCK ALARM
J1	35363-1460	14	DATA OUT

CONNECTIONS			
CONN.	TYPE	PIN #	FUNCTION
J2	USB MINI-B	1	+V
J2	USB MINI-B	2	D-
J2	USB MINI-B	3	D+
J2	USB MINI-B	4	GND
J2	USB MINI-B	5	GND
J3	SMA-FEMALE	1	REF. INPUT
J4	SMA-FEMALE	1	RF OUTPUT

UNLESS OTHERWISE SPECIFIED DIMENSIONS ARE IN INCHES
TOLERANCE ARE:
FRACTIONS DECIMALS ANGLES
+ .02
- .010

WEIGHT 15 Oz. / 425gr

FINISH
DO NOT SCALE DRAWING

CONTRACT NO.	
APPROVALS	DATE
DRAWN N.NGUYEN	10/03/11
ENGR.	
MANUF.	
Q.A.	



MICRO LAMBDA WIRELESS, INC.

MLSP SYNTHESIZER (SIDE)

SIZE	CAGE No ORN63	DWG. NO. 181 - 002	REV. A
------	-------------------------	------------------------------	------------------

A simple block diagram is shown in Figure 1. Depending on the port configuration as shown in drawing 181-001 & 181-002, the synthesizer provides a external reference input J3, a RF output J4, a DC power/serial interface port J1, and a USB Mini-B interface connector J2. The synthesizer is tuned via the J1 serial connection or the USB port J2. DC voltages of +5.0V and +15.0V, with adequate current to operate the product must be applied to J1 in order to communicate with the product.

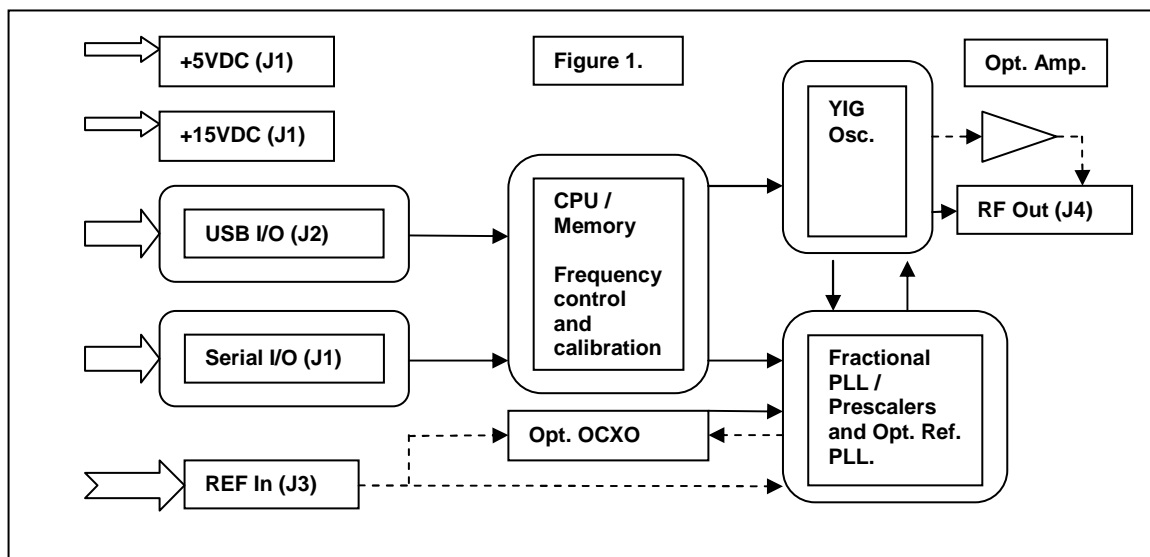

4.0 Setup and Operation

This product is designed for a 0 to 60 Degree C environment and should not be subjected to humidity >95%. Use proper ESD handling procedures. Allow for a proper heat-sink able to dissipate the total wattage/heat generated at the highest frequency setting of the unit. Verify that all external RF/microwave cables and components connected to the unit are in good working condition.

4.1 Connections

Connect to the preferred interface port, Serial or USB. USB Mini-B to USB Male - A cable for connection to a host PC USB port, the USB interface is USB 1.1 and 2.0 compatible. The serial port is a 0-5V, CMOS/TTL compatible port; it is very similar to an SPI communication port. Clock, Data and Select/Enable operate in the typical serial communication format, except that the maximum clock speed is 250 kHz. The Busy line is for handshake to the controller, a High on this line tells the controller that the synthesizer is busy and should not be selected for communication at this time. The Data Out line is used to read data from the synthesizer if a command requested it. The data is clocked into the controller by clocking out data of 0's to the MLSP and the controller reads during this time. The Data Out line will be taken high by the MLSP, when data is ready. The Busy line must be monitored. See section 6.0/6.1 serial communication for details. The Lock Alarm signal J1 pin 13 is a hardware logic signal that shows the state of the internal phase locked loop circuits.

This line should be a TTL high for the majority of the time unless the unit is stepping frequency, then it will pulse low when switching between frequencies, typically it will be low for less than 2 milliseconds.

Connect an external reference frequency (if required) to J3. Connect a +5.0 VDC and a +15 VDC power supply with adequate current to operate the product (see spec sheet) to the J1 connector; +5.0 VDC on J1 pins 5 and 6, +15.0VDC on J1 pins 1 and 2 and a common ground for both supplies on pins 3 and 4. Note the power supply inputs are protected from damage up to +/-20 VDC.

4.2 MLSP operation

Turn on the power supply voltages and verify that the current for each supply is below the maximum stated current in the specifications for your model. A 5 minute warm up is recommended before use. The unit should be operating at the last frequency it was set to before power down; this would typically be Fmin when shipped from the factory. The Lock Alarm line (J1 pin 13) should be high.

5.0 Controlling the MLSP using a personal computer

The MLSP Synthesizer can be controlled by a personal computer for Demo purposes. The requirements for this are as follows: A USB ver. 1.1 or 2.0 port on the PC, Windows XP, Windows Vista or Windows 7 (32 or 64 bit), the programs included on the MLSP Support CD and a power supply capable of supplying the DC Voltage and Current required to operate the MLSP synthesizer.

5.1 Installing the documentation and control software

The CD ROM supplied with the MLSP contains the file named **SetupMLSP.msi**. Execute this file to install the manual, documentation and control programs for PC interface. The setup file, when run, will create a folder named "MLSP Support Files" on the computer desktop with short cuts to the documentation and interface program. (Note: This setup file must be executed for the USB PC interface program to operate correctly, dll files will be installed to the system directory.)

5.2 USB Interface

The MLSP product, when connected using the USB interface, appears as a USB HID device (Human Interface Device) to the Windows operating system. The USB HID driver is supplied with the windows operating system, and is installed automatically when the unit is connected to the PC's USB port.

The MLSP may be controlled remotely via a USB connection using the supplied "MLSP PC interface.exe" program. A screen capture of this program is shown in Figure 2. Additional information is accessed via the program's pull-down menus "File" and "Help". Included in these menus are View/Print the configuration NOVO locations and data, a list of all commands that the unit will respond to, how to build a wire harness to connect to power supplies and a PC printer port and a description of NOVO locations and what is stored at each location. On the program screen you will see some limited information

about the unit. PLL Lock status is also shown; it is updated each time the “Update Info” check box is selected. Commands may be sent to and received from the unit. The unit can also be stepped up and down in frequency using the “Step Up” and “Step Down” buttons, the frequency will increment and decrement based on the frequency shown in the step size box. This number can be changed to any valid step size within the frequency range limits of the unit. The current frequency setting is also shown. The program can be used to connect to multiple units; all units that are connected to the PC’s USB ports will show up in the pull down list in the “Choose Unit #” box. If units are added after the program has been initiated or the MLSP(s) were powered down for a time, press the “Refresh” button to update the list. A sweep mode feature is included to allow the unit to sweep (Step and Dwell) at each frequency based on the step size and dwell time text boxes. Start and Stop frequency can also be adjusted for a narrower range, if needed. Four sweep modes are selectable; Auto = continuous sweep across the start/stop range retraces from stop frequency and repeats. Single = one single sweep from start to stop. Manual = unit will take one step up or down from the current frequency when the step up/down keys are pressed. Frequency List mode = frequency sweep based on a user generated list of frequencies. To configure this mode, click the Edit List button and input one frequency per line (In MHz, i.e. 2450.125) in the text editor and save/exit. The file is created and named for the serial number of the unit. Make sure the List Mode is selected and choose your desired sweep mode, then press Run. The unit will step the frequency based on your list of frequencies and the dwell time selected. Frequencies can be increasing, decreasing or random. Multiple versions of the program can be executed to sweep or communicate with more than one unit at a time.

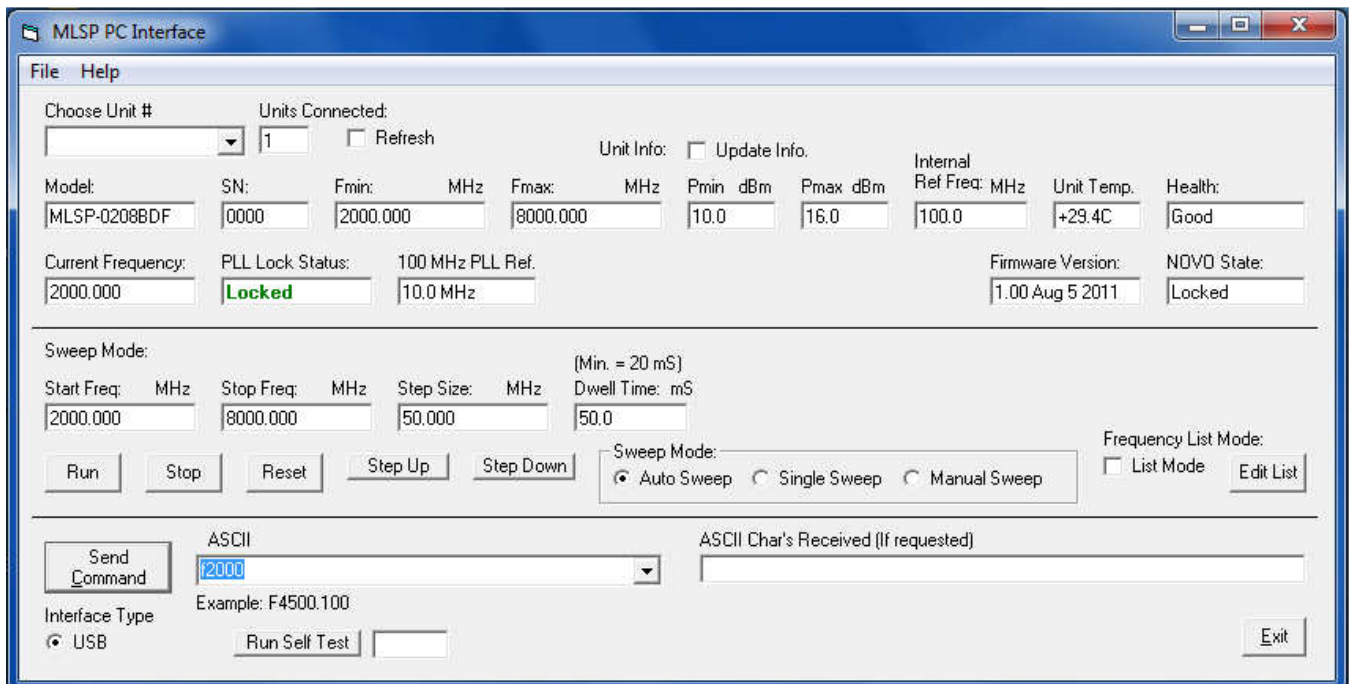

Figure 2

5.3 USB HID PC Interface example C# source code

Included in the installed support files folder is an example of a simple USB HID interface program written in C#. The project file and source code were written using Microsoft Visual Studio Express 2010, C Sharp. Visual Studio Express 2010, C Sharp can be downloaded for free at <http://www.microsoft.com/visualstudio/en-us/products/2010-editions/visual-csharp-express>. After you register this free version of the programming environment, you can create and edit C# programs.

This source code will allow you to get started integrating the MLSP USB communication into your own C programs. The example program is a simple interface in which you can send and receive ASCII characters. The interface tests for a connection to the MLSP synthesizer by looking for a return string indentifying the MLSP unit after searching through all attached USB devices.

An executable version of the program is located on the CD in the directory - \MLSP USB HID PC Interface C# Example\bin\x86\Release\. The file name is – MLSP USB HID PC Interface C Example.exe. A screen shot of the interface is shown in figure 3.

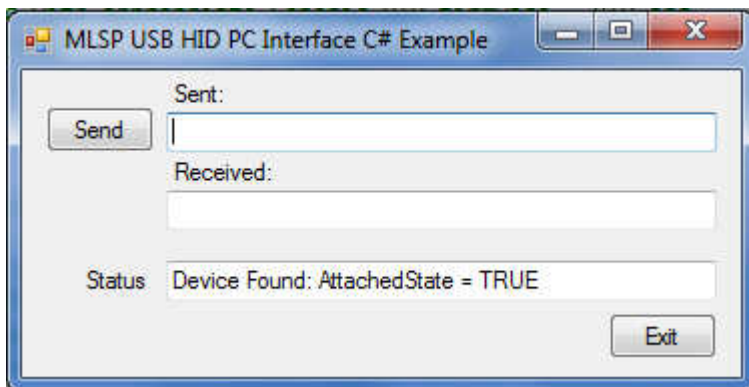

Figure 3

6.0 Serial interface

The MLSP can be programmed using a 5 wire serial bus. The timing diagram is shown in Figure 4. The Five control lines are as follows:

SELECT (J1 – Pin 11)	Input	Active Low. Enables the shifting of data into the internal command buffer. Also serves as a command terminator when it goes HIGH. The status of the BUSY line should be checked before activating this line. Note: All command + data, command strings must be sent using a single Select Line Cycle. When low, Busy is high.
CLOCK (J1 – Pin 9)	Input	Data is clocked into the unit on the rising edge (Positive Edge Clocked) and DATA OUT is valid at this time. The maximum clock rate of this line is 2 usec. For best performance the status of the DATA OUT line should be checked before sending the first Clock. This line should be maintained in a LOW state at the application of Select to prevent confusion.
DATA IN (J1 – Pin 10)	Input	Input data pin. Data is sent MSB first. Data must be stable 1 usec. Before the CLOCK line goes high and 1 usec. After the clock goes low. (Setup / Hold time)
BUSY (J1 – Pin 12)	Output	This line is used to indicate that the unit is busy processing other commands or doing its internal housekeeping. Before sending a Select = TRUE the status of this line should be checked to ensure that it is LOW (NOT Busy). Any command initiated by setting Select Low while BUSY is High may result in lost data and uncertain results. NOTE: The unit can be programmed without using this line if sufficient time is allowed between Clocks and between commands. The time required varies between commands. This mode is not recommended as there are some events that occupy the microcontroller other than the serial communications.
DATA OUT (J1 – Pin 14)	Output	This line is used to pass internal information from the synthesizer to the user. Data is guaranteed to be valid on the falling edge of the clock signal. Data is sent out MSB first. In addition, this line is used as a communication 'handshake' line. Once SELECT has gone LOW the DATA OUT line will be taken HIGH to indicate that the unit is listening. It will remain HIGH until the first data is sent out which is initiated by the first rising edge of CLOCK. DATA OUT will be returned to LOW after Select has been released.

For the following information, please reference the above documentation regarding Busy and Data out.

Recommended send data sequence: The format is one select per command string. The string length is variable up to 16 ASCII characters. A decimal point is required for resolution less than 1.0 MHz. The unit will accept a frequency command with a resolution of 1.0 Hz, and it will try to get as close to the frequency requested as it can, typically ≤ 10.0 Hz accuracy. So the command to set the frequency F8000.1 would be sent as follows: Set select low, clock out 01000110 00111000 00110000 00110000 00110000 00101110 00110001 (Ignore spaces, only used to single out each ASCII char), then set select high. The unit should go to 8000.1 MHz. When select goes high, this tells the unit that the user is done and to start interpreting the command. If the command is not understood, the unit will do nothing.

Recommended read data sequence: The returned data is variable in length; however it is recommended that the full 16 bytes of data be read to clear the buffer. Set select low, send the desired read command and set select high. The unit interprets the command and places the requested data in its buffer. Then set select low and clock out 16 ASCII nulls while clocking in the data, then set select high. Example: To read the units internal temperature, set select low and send ASCII T (01010100), set select high. Set select low and send 16 00000000 while reading the data line and clocking in bits. Set select high. The information should be similar to +25.0C, in ASCII. All of the memory locations in the unit can be read in this manner, using the R command.

In addition to the lines above there is a unit status line, LOCK ALARM status (J1- Pin 13), which is a static line. This TTL output (High = Locked) indicates the overall health of the unit – specifically, that all of the internal phase locked loops are locked.

The MLSP serial interface lines operate on internal 3.3V logic of a PIC microcontroller; this should allow the unit to communicate in systems operating with 2.5V, 3.3V and 5.0V serial control lines.

6.1 Serial interface timing diagram:

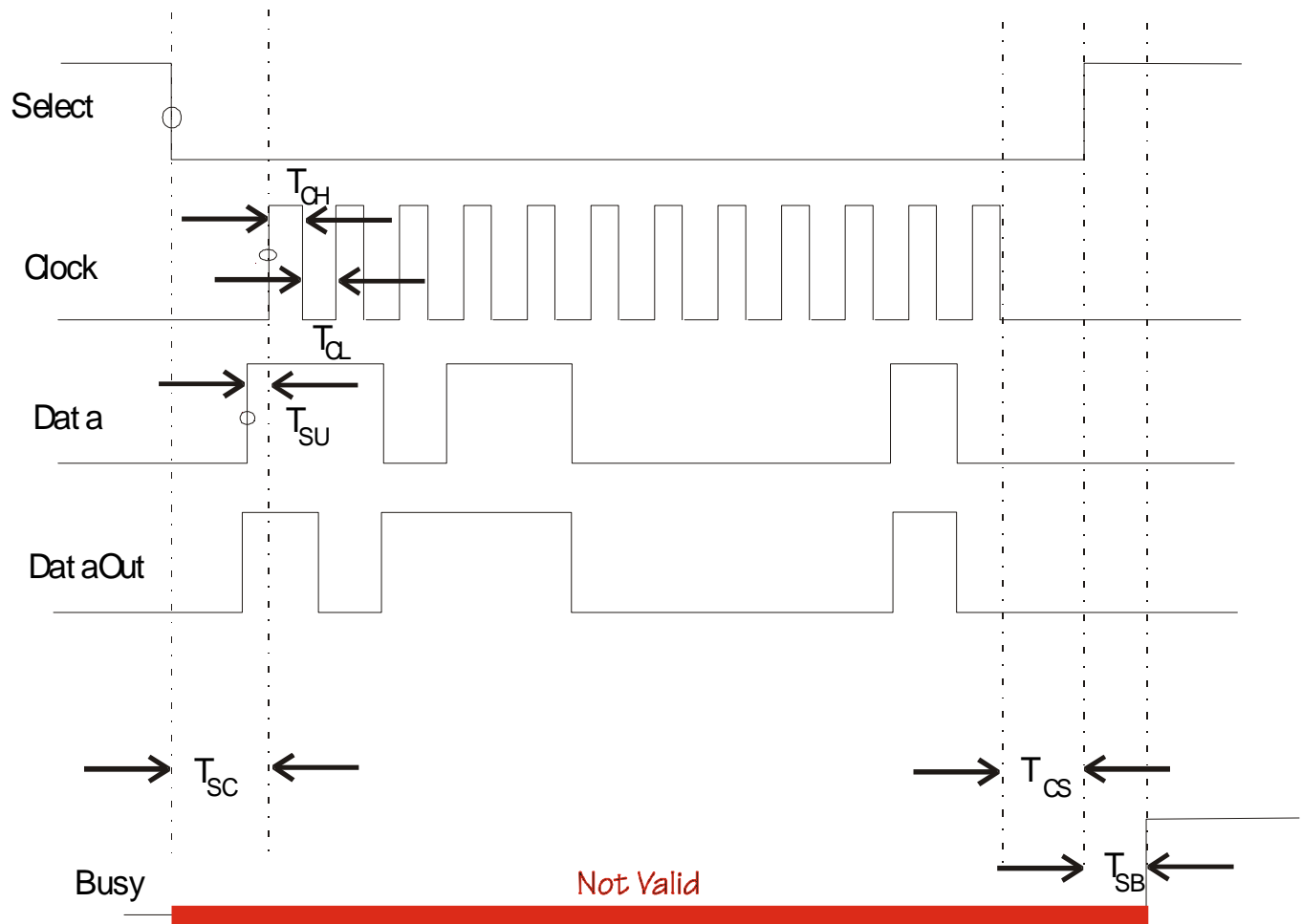

Figure 4

- $T_{sc} > 2 \text{ usec}$ select low before first clock
- $T_{cs} > 2 \text{ usec}$ clock low before chip select high
- $T_{su} > 2 \text{ usec}$ data stable before rising edge of clock
- $T_{ch} > 2 \text{ usec}$ minimum clock high time
- $T_{cl} > 2 \text{ usec}$ minimum clock low time
- $T_{sb} > 10 \text{ usec}$ (time to wait before sampling 'BUSY')

Data/Clock Setup time = $>1 \text{ usec}$.

Data/Clock Hold time = $T_{ch} + 1 \text{ usec}$.

7.0 Communication syntax

The following table describes the commands that the MLSP supports. This is a custom syntax created by Micro Lambda Wireless, Inc. All commands are sent and received in ASCII format. The commands are NOT case sensitive. These commands can be used with all forms of communication (USB and Serial).

Command	Function	Comment
?	Report Status – Bits, D0 = 100 MHz lock, D1 = YIG PLL, D6 = self test, D7 = NOVO lock	Typical return = 11000011
F	Frequency (ASCII) (Dec. #)	ASCII freq in MHz: xxxxx.xxxxx; (example: F12345.678900)
L	Set Level of RF Power option (Option G)	Sets the Leveling DAC to a specific Level (L-0.5) (L9.5)
MR	Recall a user saved frequency setting from memory location (MR25)	0-99, stored @ NOVO location 200-299
MS	Save current frequency setting of unit to memory location (MS75)	0-99, stored @ NOVO location 200-299
POWERON	Turns ON internal supplies related to +15V input	Turns ON YIG / PLL / Analog supplies. (default = on power up)
POWEROFF	Turns OFF internal supplies related to +15V input (Low power state)	Digital logic and Xtal Osc. Supplies are always on
R	Read a NOVO location	R0 returns model number
SP	Synthesizer preset to factory settings.	Copy NOVO Loc. 900-960 to 0-60
SR	Soft PIC Reset	Reset PIC, clear var. run PIC code from start; (example: SR)
ST	Self Test	Execute internal test; 1 = Pass; (example: SR, then read data)
T	Read internal temp.	Returns ASCII chars, reading in Deg. C; (example: T, then read data)
V1	Read YIG PLLV (typical Range = 1V to 12V)	6.75V = normal; (example: V1, then read data)
V2	Read 100 MHz PLL V (typical Range = 1V to 12V)	5.00V = normal; (example: V2, then read data)
V3	Read internal +2.5V voltage	2.50V = normal; (example: V3, then read data)
V4	Read internal +3.3V voltage	3.30V = normal; (example: V4, then read data)
V5	Read internal +5.0V voltage	5.00V = normal; (example: V5, then read data)
V6	Read internal +6.75V voltage	6.75V = normal; (example: V6, then read data)
V7	Read internal +12.0V voltage	12.00V = normal; (example: V7, then read data)
V8	Read internal +13.5V voltage	13.50V = normal; (example: V8, then read data)
V9	Read internal -5.0V voltage	-5.00V = normal; (example: V9, then read data)
R0000	Model Number (Example = R0) Read Location 0.	MLSP-0208CD ("W" blocked with NOVO locked.) (R/W = 16 Bytes)
R0001	Serial Number	0002
R0002	Internal Xtal Serial Number (Optional)	0940-002
R0003	Fmin, in MHz	2000 (unit is tunable 100.0 MHz below Fmin.)
R0004	Fmax, in MHz	8000 (unit is tunable 100.0 MHz above Fmax.)
R0005	Current Internal Reference Frequency Setting - MHz	R# = 1 – 200 MHz, typ. = 100
R0006	RF min, in dBm	10.0
R0007	RF max, in dBm	15.0
R0008	Temp min, in Deg. C	0
R0009	Temp max, in Deg. C	60
R0010	Highest Temp reached, in Deg. C	59.8
R0011	NOVO State - Locked/Unlocked	Locked
R0012	Firmware Version & date	1.5 Nov 16 2011
R0013	Unit Health Status – "Good" or Self test failure information	Good or Fail V5 as example
R0014	Unit Calibration Status - Yes/No	Yes
R0015	Self Test Results - Pass/Fail	Pass
R0016	Current Output Frequency setting - MHz	2500
R0017	Internal Xtal Setting – Int or Ext or ExtXtal	ExtXtal (3 modes; Internal Xtal, External and External with Xtal.)
R0018	Xtal DAC cal # (Hex)	0000-FFFF
R0019	Coarse DAC Fmin cal # (Hex)	0000-FFFF

Command	Function	Comment
R0020	Coarse DAC Fmax cal # (Hex)	0000-FFFF
R0021	Current Coarse DAC setting (Hex)	0000-FFFF
R0022	Current Fine DAC interpolated setting (Hex)	0000-FFFF, 8000 nominal
R0023	Current Loop Gain (CP) setting, 0-31 (Dec)	31 charge pump current
R0024	Current Microwave Divider (DV) setting, 1, 2, 4, 8 (Dec)	2 (Sets external Prescaler to 1, 2, 4, or 8)
R0025	Current Reference divider setting	2 Ref Div
R0026	Coarse Cal status; Yes / No	Yes
R0027	Fine Cal status; Yes / No	Yes
R0028	Xtal Cal status; Yes / No / N/A	Yes N/A if Internal Xtal setting = Ext or ExtXtal
R0029	External reference freq. In MHz for 100 MHz PLL (ExtXtal mode)	i.e.: 10 = 10 MHz external reference. 1.0 MHz increments only
R0030	Current loop gain (LG) setting; 0-127 (Dec), U29 gain setting.	written by PIC after LG command, read at boot and sent to U29
R0031	Customer part number, if shown on P.O.	123-45-6789 (Shown on unit label as PN:)
R0032	Frequency resolution in MHz (or Step Size)	0.001 = 1.0 kHz
R0033	Spurious Spec., in dBc	-60
R0034	Harmonics Spec., in dBc	-12
R0035	Phase Noise Spec. @ 100 Hz Offset, in dBc/Hz	-85
R0036	Phase Noise Spec. @ 1 kHz Offset, in dBc/Hz	-90
R0037	Phase Noise Spec. @ 10 kHz Offset, in dBc/Hz	-100
R0038	Phase Noise Spec. @ 100 kHz Offset, in dBc/Hz	-120
R0039	Phase Noise Spec. @ 1 MHz Offset, in dBc/Hz	-140
R0040	Switching Speed, any step, in mS	5.0
R0041	+15V Supply current Max, in mA	750
R0042	+5V Supply current Max, in mA	300
R0043	Level Control Option installed?	Yes / No
R0044	Level Control Maximum Power Limit, in dB	10.0
R0045	Level Control Minimum Power Limit, in dB	-10.0
R0046	Level Control Cal Point Frequency Step (Cal data taken every - ___ MHz)	100.0 MHz
R0047	Level Control Cal Point Level step (Cal data taken every - ___ dB)	1.0
R0048	Current RF Level Setting, in dBm	9.5
R0049	Current Level DAC setting (Hex, ASCII)	AF61
R0050	Level Control CAL Status (Is Level option calibrated)	Yes / No
R0051	Level flatness Spec. in +/- dB (+/- 2.0 = 4.0 total)	2.0
R0052		
R0053		
R0054		
R0055		
R0056		
R0057		
R0058	MLWI Sales (Job) number	18-0024
R0059	MLWI Product Outline Drawing # and Revision	181-003 G
R0060	Power State (Power supplies on or off) On power-up will default to ON!	"ON" or "OFF"(Low power) - Show status of "poweron" and "poweroff" commands.
....		
200-299	User Saved / Recalled frequency setting locations, (0-99)	Frequency stored in MHz
...		
R 900-960	Config data backup safe area, SF - save factory stores data here.	Backup copy of NOVO location 0000 to 0060 (Config Data)
....		
R1000-2047	DAC cal data, stored in 25 MHz increments, Fmin-100 to Fmax+100 MHz, 8000 Nom.	Stored in 16 bit HEX numbers (ASCII format)

8.0 Hardware installation information

The unit may be installed into a system using four #4-40 X 1.25" long flat head screws, inserted from the top, in the 4 corner mounting holes. Alternately, four #8-32 X 0.5" screws can be attached from the bottom side through the mounting surface, in the 4 corner mounting holes. The Molex connector (J1) and the mating connector information are shown in the drawing numbers 181-001 and 181-002 in this document. The USB connector is the standard Mini-B style.

9.0 Technical Support

For Technical support please contact:

Micro Lambda Wireless, Inc.
46515 Landing Pkwy.
Fremont, CA 94538
Ph: (510) 770-9221
Fax: (510) 770-9213

Email: sales@microlambdawireless.com

You can visit our website at <http://www.microlambdawireless.com> for updated information, specifications and downloads.

10.0 Warranty

Seller warrants for a period of twelve (12) months from the date of original shipment that the products will be free from defects in material and workmanship and design (if of Micro Lambda Wireless, Inc. design) and will be in conformity with applicable specifications and drawings and all other contractual requirements. However, this warranty shall not apply to any product which that has been subjected to misuse, misapplication, accident, improper installation, neglect, unauthorized repair, alteration, adjustment, inundation or fire. See the complete warranty and return policy document number 201-005 Rev- at our website at <http://www.microlambdawireless.com>.