

FEATURES

- 700 MHz To 40 GHz
- Compensation for Temperature Drift
- Voltage Regulators for Improved Stability
- 16 Bit Tuning Resolution

APPLICATIONS

Frequency Converters
Portable Test Equipment

DESCRIPTION

Micro Lambda **MLOB, MLOS, MLXB, MLXS and MLXS-T Series** Electromagnet YIG Oscillators are available with integrated serial driver circuits. These drivers eliminate the need for customers to design or develop their own driver circuits and sophisticated test and alignment procedures. Integrating a driver at Micro Lambda's factory ensures peak performance. Alignment and compensation with the particular YIG oscillator can be maximized down to the component level.

All drivers in this series provide input voltage regulators, reverse voltage/dataline protection and compensation circuits to improve frequency drift. All voltages required by the YIG oscillator, except the heater inputs are supplied by the voltage regulators.

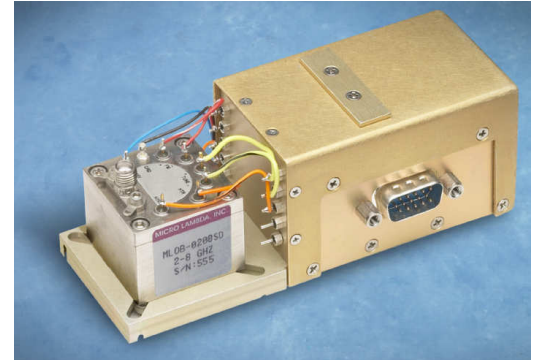

COMMERCIAL SERIAL DRIVERS		.7-40 GHz YTOs, SD & SG SERIES
DRIVER INPUT & RESPONSE		SPECIFICATION (0 to +65 deg. C)
Tuning Command		Start Word (all 0's) = Lowest Frequency Stop Word (all 1's) = Highest Frequency
Tuning Resolution		16 BIT Positive Logic (Fmax-Fmin)/65,535 Bit Resolution
Tuning Accuracy (excluding hysteresis)		See Table
Tuning Speed		5 mS for 1 GHz step to within ± 10 MHz. (residual FM is 100 kHz Pk-Pk)
Main Driver Inputs		
Supply Voltage & Current		+15 V \pm .5 V @ Oscillator Tuning Current +50 mA, Max. -15 V \pm .5 V @ 50 mA, (Plus Oscillator -5 Vdc Current if any) Max.
Supply Voltage Pushing		\pm 100 kHz, Max. @ \pm .5 Vdc (2-3000 kHz)
Supply Voltage Ripple		10 mV Ripple Pk-Pk from 2 kHz to 3 MHz
Ground		Chassis Ground
YIG Heater Voltage & Current		+24 Vdc \pm 4 Vdc @ 300 mA surge for 2 seconds, 25 mA steady state Polarity independent : ± 12 Vdc or ± 15 Vdc acceptable
Digital Interface		The MLWI digital driver interface is a standard 3-wire connection compatible with SPI/QSPI/MICROWIRE interfaces. The chip-select input (CSELECTn) frames the serial data loading at the data input pin (DATA). Immediately following CSELECTn's high-to-low transition, the data is shifted synchronously and latched into the input register on the rising edge of the serial-clock input (CLOCK). After 16 data bits have been loaded into the serial input register, it transfers its contents to the DAC latch on CSELECTn's low-to-high transition (Figure 2). Note that if CSELECTn does not remain low during the entire 16 CLOCK cycles, data will be corrupted. In this case, reload the DAC latch with a new 16-bit word.

SD-SERIES — CONT.

YIG Tuned Oscillators with Serial Drivers

Power-On Reset

The MLWI digital driver has a power-on reset circuit to set the DAC's output to OV(F-min) in unipolar mode when VDD is first applied. This ensures that unwanted DAC output voltages will not occur immediately following a system power-up, such as after power loss.

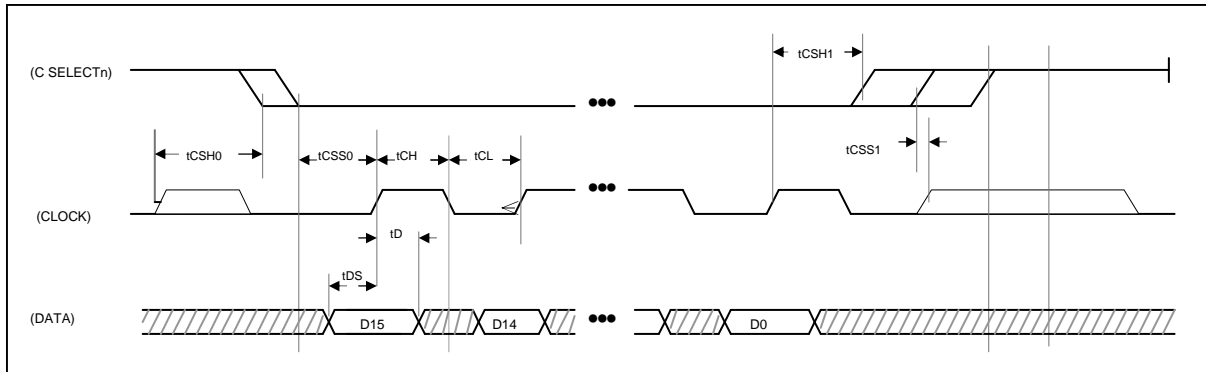

Figure 1. Timing Diagram

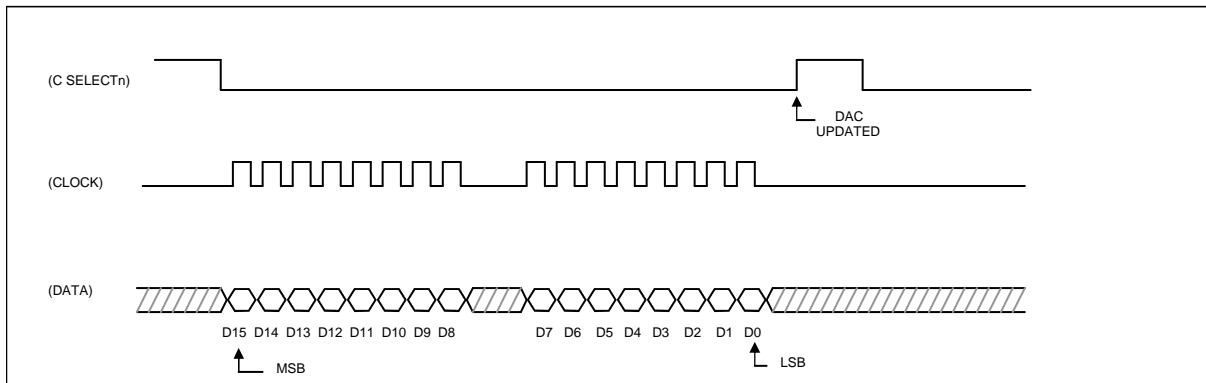

Figure 2. 3-Wire Interface Timing Diagram

TIMING CHARACTERISTICS

PARAMETER	SYMBOL	CONDITIONS	MIN	TYP	MAX	UNITS
CLOCK Frequency	fCLK				10	MHz
CLOCK Pulse Width High	tCH		45			ns
CLOCK Pulse Width Low	tCL		45			ns
CSn Low to CLOCK High Setup	tCSS0		45			ns
CSn High to CLOCK High Setup	tCSS1		45			ns
CLOCK High to CSn Low Hold	tCSH0		30			ns
CLOCK High to CSn High Hold	tCSH1		45			ns
DATA to CLOCK High Setup	tDS		40			ns
DATA to CLOCK High Hold	tDH		0			ns
VDD High to CSn Low (power-up delay)				20		μs

SD-SERIES — CONT.

FM Coil Driver (SG Option)

Voltage	± 10 V
Current	± 100 mA
Input Impedance	1 k-Ohms
Sensitivity (Note 1)	± 2.5 MHz/V
Frequency Deviation	± 25 MHz

Note: 1. FM Coil Sensitivity Adjustment Available. Sensitivity Stated is Average Over Frequency Range.

PERFORMANCE SPECIFICATIONS

1.25" Cube YIG Oscillator with Positive Input Serial Drivers (0°C to +65°C)

Model Number	Frequency GHz	Accuracy (MHz) *	Current +15 V (mA)	Current -15 V (mA)	Outline Drawing	Outline Drawing (SG Option)
Octave Bands						
MLOB-0102SD	1-2	± 3	200	50	11-124	11-125**
MLOB-0204SD	2-4	± 6	300	50	11-124	11-125**
MLOB-0408SD	4-8	± 8	550	50	11-124	11-125**
MLOB-0812SD	8-12.4	± 12	780	50	11-124	11-125**
MLOB-1218SD	12-18	± 14	1050	50	11-124	11-125**
Multi-Octave Bands						
MLOB-0702SD	.7-2	± 3	250	50	11-124	11-125**
MLOB-0704SD	.7-4	± 5	350	50	11-124	11-125**
MLOB-0306SD	3-6	± 6	450	50	11-124	11-125**
MLOB-0208SD	2-8	± 12	550	50	11-124	11-125**
MLOB-0212SD	2-12.4	± 15	780	100	11-124	11-125**
MLOB-0310SD	3.5-10.5	± 15	675	100	11-124	11-125**
MLOB-0412SD	4-12.4	± 15	780	100	11-124	11-125**
MLOB-0716SD	7-16	± 18	900	50	11-124	11-125**
MLXB-0618SD	6-18	± 25	1050	100	11-124	11-125**
MLOB-0818SD	8-18	± 18	1050	50	11-124	11-125**
MLXB-0818SD	8-18	± 18	1050	50	11-124	11-125**
MLOB-0820SD	8-20	± 30	1175	50	11-124	11-125**
MLXB-0820SD	8-20	± 30	1175	50	11-124	11-125**

* Accuracy includes frequency drift and linearity errors over the temperature range.

** Outline Drawing Available from Factory.

SD-SERIES — CONT.

Cylindrical YIG Oscillators with Positive Input Serial Drivers (0° C to +65° C)

Model Number	Frequency GHz	Accuracy (MHz) *	Current +15 V (mA)	Current -15 V (mA)	Outline Drawing	Outline Drawing (SG Option)
Octave Bands						
MLOS-0102SD	1-2	± 3	200	50	11-129	11-128**
MLOS-0204SD	2-4	± 6	300	50	11-129	11-128**
MLOS-0408SD	4-8	± 8	550	50	11-129	11-128**
MLOS-0812SD	8-12.4	± 12	780	50	11-127	11-118**
MLOS-1218SD	12-18	± 14	1050	500	11-127	11-118**
Multi-Octave Bands						
MLOS-0702SD	.7-2	± 6	250	50	11-129	11-128**
MLOS-0704SD	.7-4	± 8	350	50	11-129	11-128**
MLOS-0306SD	3-6	± 6	450	50	11-129	11-128**
MLOS-0208SD	2-8	± 12	550	50	11-129	11-128**
MLOS-0310SD	3.5-10.5	± 15	675	100	11-129	11-128**
MLOS-0212SD	2-12.4	± 15	780	100	11-129	11-128**
MLOS-0412SD	4-12.4	± 15	780	100	11-129	11-128**
MLOS-0716SD	7-16	± 18	900	50	11-127	11-118**
MLXS-0618SD	6-18	± 25	1050	100	11-127	11-118**
MLOS-0818SD	8-18	± 18	1050	50	11-127	11-118**
MLXS-0818SD	8-18	± 18	1050	50	11-127	11-118**
MLOS-0820SD	8-20	± 30	1175	50	11-127	11-118**
MLXS-0820SD	8-20	± 30	1175	50	11-127	11-118**
MLXS-0218SD	2-18	± 35	1150	100	11-127	11-118**
MLXS-0218TSD ***	2-18	± 35	1150	100	11-126	11-115**
MLXS-0220SD	2-20	± 35	1175	100	11-127	11-118**
MLXS-0220TSD ***	2-20	± 35	1175	100	11-126	11-115**
Millimeter Wave Bands						
MLOS-1826SD	18-26	± 30	1200	50	11-152**	11-151**
MLOS-1724SD	17-24	± 30	1100	50	11-152**	11-151**
MLOS-1840SD	18-40	± 40	1200	50	11-152**	11-151**
MLOS-2040SD	20-40	± 40	1200	50	11-152**	11-151**
MLOS-2640SD	26-40	± 40	1200	50	11-152**	11-151**

* Accuracy includes frequency drift and linearity errors over the temperature range.

** Outline Drawing Available from Factory.

***Units are Switched Two-Band units.

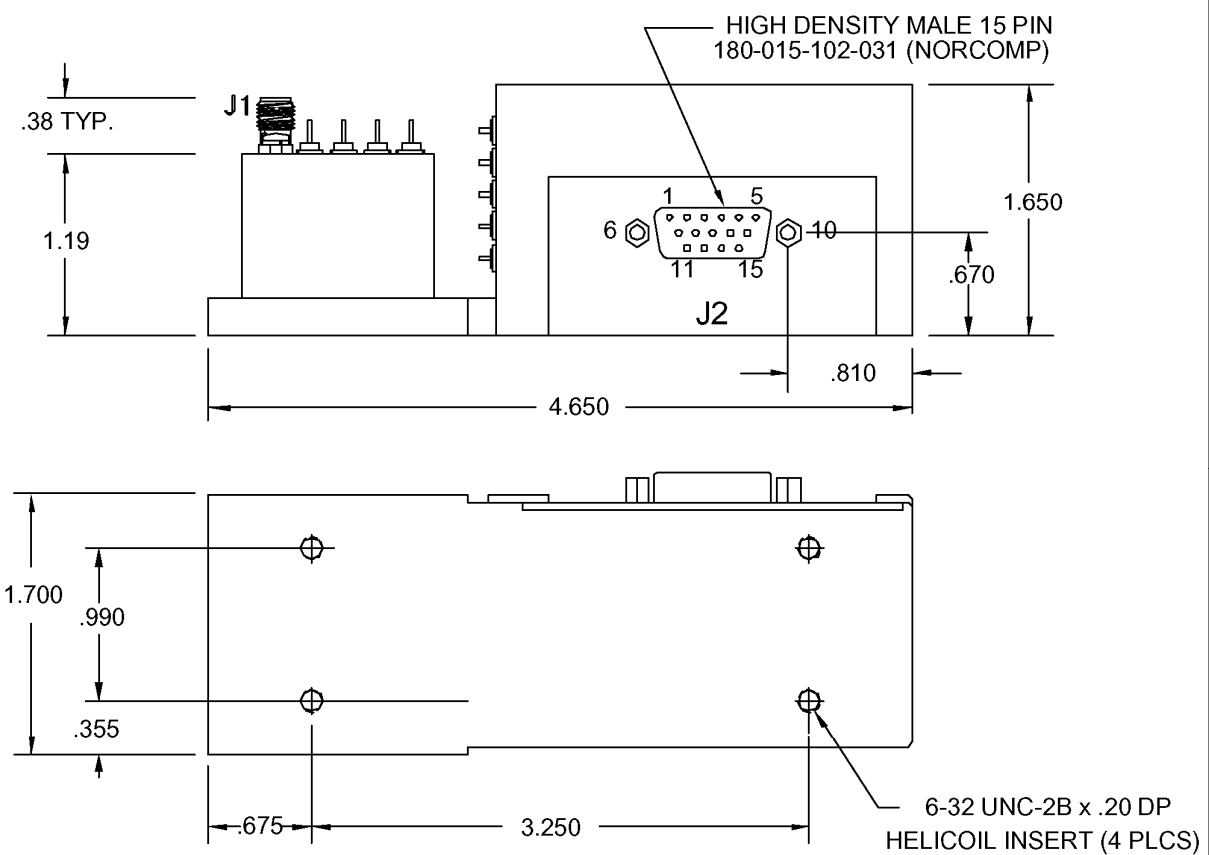

NOTES :

- 1. - DIMENSIONS ARE IN INCHES
- 2. - SUPPLY & GROUND WIRES = 20-22 GAUGE
ALL OTHER WIRES = 24-26 GAUGE
- 3. - THERMAL COMPOUND REQUIRED BETWEEN
BASE PLATE AND MOUNTING SURFACE

(*): TTL BAND SEL. 0=8-Fmax ; 1=2-8 GHz

CONNECTIONS			
CONN.	TYPE	PIN #	FUNCTION
J1	SMA	THD	RF OUT
J2	DB15 MALE	1	CLOCK
J2	DB15 MALE	2	DATA
J2	DB15 MALE	3	C SELECT N
J2	DB15 MALE	4	GROUND
J2	DB15 MALE	5	- V SUPPLY
J2	DB15 MALE	6	+ V SUPPLY
J2	DB15 MALE	7	HEATER 1
J2	DB15 MALE	8	HEATER 2
J2	DB15 MALE	9	+ FM
J2	DB15 MALE	10	- FM
J2	DB15 MALE	11	TTL BAND SELECT (*)
J2	DB15 MALE	12	N/C
J2	DB15 MALE	13	N/C
J2	DB15 MALE	14	N/C
J2	DB15 MALE	15	N/C

(*): REQUIRED FOR DUAL OSC. ONLY

UNLESS OTHERWISE SPECIFIED DIMENSIONS ARE IN INCHES TOLERANCE ARE: FRACTIONS DECIMALS ANGLES ▲ XX ▲ .000 ▲ ▲ .XX ▲ .005	CONTRACT NO.	
	APPROVALS	DATE
WEIGHT 23 oz.	DRAWN	5/25/04
	ENGR	
FINISH	MANUF.	
	Q.A.	
DO NOT SCALE DRAWING		



MICRO LAMBDA WIRELESS, INC.

STD. 1.25" OSC. WITH SERIAL DRIVER

SIZE	CAGE No 0RN63	DWG. NO. 11 - 124	REV.
------	------------------	----------------------	------

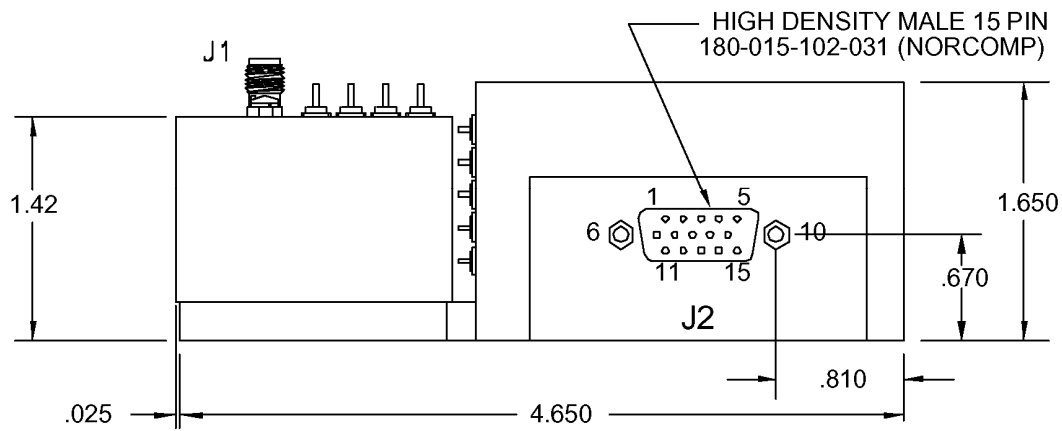

NOTES :

1. - DIMENSIONS ARE IN INCHES
2. - SUPPLY & GROUND WIRES = 20-22 GAUGE
ALL OTHER WIRES = 24-26 GAUGE
3. - THERMAL COMPOUND REQUIRED BETWEEN
BASE PLATE AND MOUNTING SURFACE

(*) : TTL BAND SEL. 0=8-Fmax ; 1=2-8 GHz

CONNECTIONS			
CONN.	TYPE	PIN #	FUNCTION
J1	SMA	THD	RF OUT
J2	DB15 MALE	1	CLOCK
J2	DB15 MALE	2	DATA
J2	DB15 MALE	3	C SELECT N
J2	DB15 MALE	4	GROUND
J2	DB15 MALE	5	- V SUPPLY
J2	DB15 MALE	6	+ V SUPPLY
J2	DB15 MALE	7	HEATER 1
J2	DB15 MALE	8	HEATER 2
J2	DB15 MALE	9	+ FM
J2	DB15 MALE	10	- FM
J2	DB15 MALE	11	TTL BAND SELECT (*)
J2	DB15 MALE	12	N/C
J2	DB15 MALE	13	N/C
J2	DB15 MALE	14	N/C
J2	DB15 MALE	15	N/C

(*) REQUIRED FOR DUAL OSC. ONLY

UNLESS OTHERWISE SPECIFIED DIMENSIONS ARE IN INCHES TOLERANCE ARE:

FRACTIONS DECIMALS ANGLES
 XX.XX ±.003
 XXX.XXX ±.005

WEIGHT 23 oz.

FINISH

DO NOT SCALE DRAWING

CONTRACT NO.

APPROVALS DATE

DRAWN N NGUYEN 5/25/04

ENGR

MANUF

Q A



MICRO LAMBDA WIRELESS, INC.

LOW BAND YTO (1.75") WITH SERIAL DRIVER

SIZE

CAGE NO
0RN63

DWG NO.

11 - 129

REV.

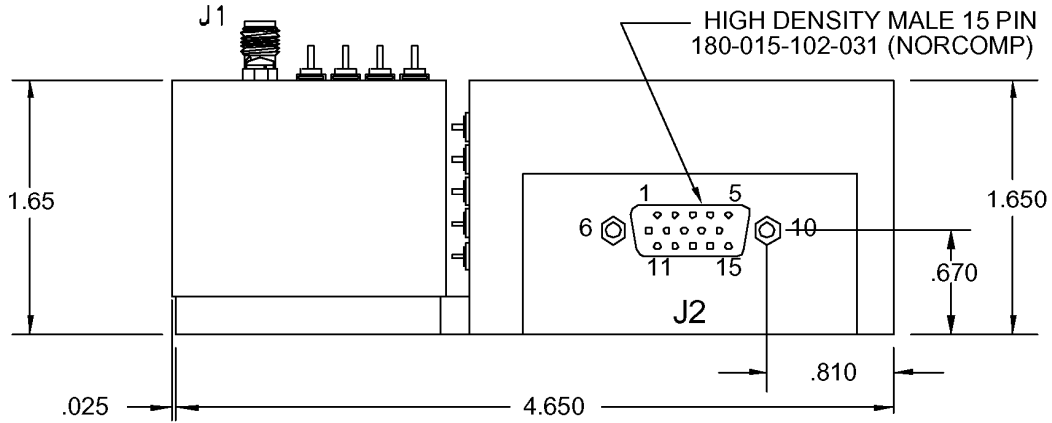

NOTES :

1. - DIMENSIONS ARE IN INCHES
2. - SUPPLY & GROUND WIRES = 20-22 GAUGE
ALL OTHER WIRES = 24-26 GAUGE
3. - THERMAL COMPOUND REQUIRED BETWEEN
BASE PLATE AND MOUNTING SURFACE

(*) : TTL BAND SEL. 0=8-Fmax ; 1=2-8 GHz

CONNECTIONS

CONN.	TYPE	PIN #	FUNCTION
J1	SMA	THD	RF OUT
J2	DB15 MALE	1	CLOCK
J2	DB15 MALE	2	DATA
J2	DB15 MALE	3	C SELECT N
J2	DB15 MALE	4	GROUND
J2	DB15 MALE	5	- V SUPPLY
J2	DB15 MALE	6	+ V SUPPLY
J2	DB15 MALE	7	HEATER 1
J2	DB15 MALE	8	HEATER 2
J2	DB15 MALE	9	+ FM
J2	DB15 MALE	10	- FM
J2	DB15 MALE	11	TTL BAND SELECT (*)
J2	DB15 MALE	12	N/C
J2	DB15 MALE	13	N/C
J2	DB15 MALE	14	N/C
J2	DB15 MALE	15	N/C

(*) REQUIRED FOR DUAL OSC. ONLY

UNLESS OTHERWISE SPECIFIED DIMENSIONS
ARE IN INCHES
TOLERANCE ARE :

FRACTIONS	DECIMALS	ANGLES
•	xx ▲ .020	
•	xxx ▲ .005	

WEIGHT
23 oz.

FINISH

DO NOT SCALE DRAWING

CONTRACT NO.

APPROVALS DATE

DRAWN N NGUYEN 5/25/04

ENGR.

MANUF. Q.A.



MICRO LAMBDA WIRELESS, INC.

HIGH BAND YTO (1.75") WITH SERIAL DRIVER

SIZE

CAGE No
ORN63

DWG NO.

11 - 127

REV.

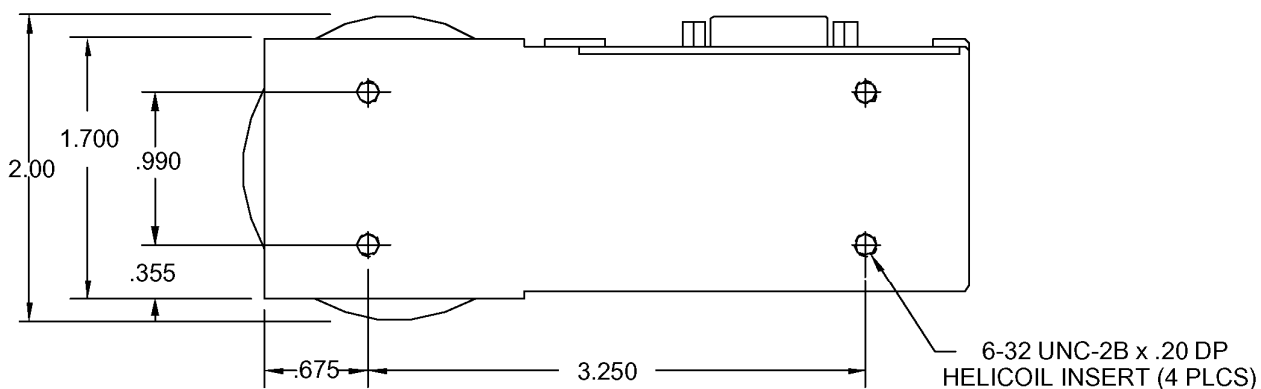
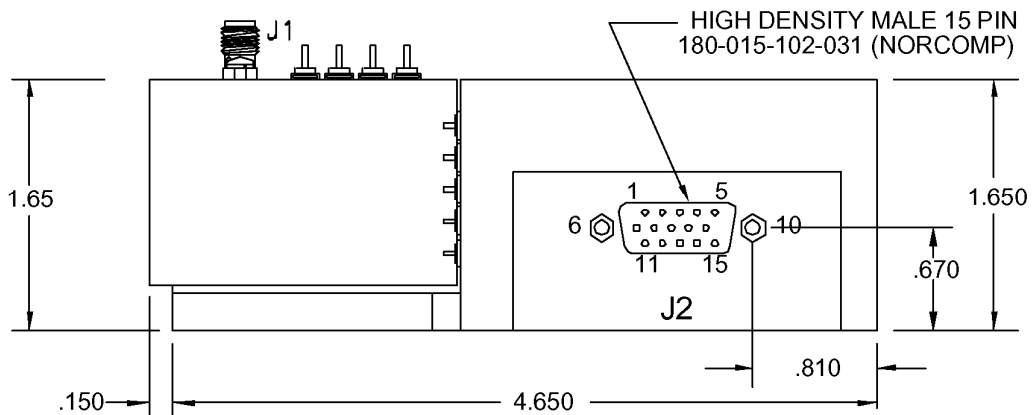

NOTES :

1. - DIMENSIONS ARE IN INCHES
2. - SUPPLY & GROUND WIRES = 20-22 GAUGE
ALL OTHER WIRES = 24-26 GAUGE
3. - THERMAL COMPOUND REQUIRED BETWEEN
BASE PLATE AND MOUNTING SURFACE

(*) : TTL BAND SEL. 0=8-Fmax ; 1=2-8 GHz

CONNECTIONS			
CONN.	TYPE	PIN #	FUNCTION
J1	SMA	THD	RF OUT
J2	DB15 MALE	1	CLOCK
J2	DB15 MALE	2	DATA
J2	DB15 MALE	3	C SELECT N
J2	DB15 MALE	4	GROUND
J2	DB15 MALE	5	- V SUPPLY
J2	DB15 MALE	6	+ V SUPPLY
J2	DB15 MALE	7	HEATER 1
J2	DB15 MALE	8	HEATER 2
J2	DB15 MALE	9	+ FM
J2	DB15 MALE	10	- FM
J2	DB15 MALE	11	TTL BAND SELECT (*)
J2	DB15 MALE	12	N/C
J2	DB15 MALE	13	N/C
J2	DB15 MALE	14	N/C
J2	DB15 MALE	15	N/C

(*) REQUIRED FOR DUAL OSC. ONLY

UNLESS OTHERWISE SPECIFIED DIMENSIONS ARE IN INCHES
TOLERANCE ARE:
FRACTIONS DECIMALS ANGLES
• xx .000
• xxx .005

WEIGHT 23 oz.

FINISH

DO NOT SCALE DRAWINGS

CONTRACT NO.	
APPROVALS	DATE
DRAWN N.NGUYEN	7/06/04
ENGR.	
MANUF.	
Q.A.	



MICRO LAMBDA WIRELESS, INC.

2.0" OSC. WITH SERIAL DRIVER

SIZE	CAGE No ORN63	DWG. NO. 11 - 126	REV.
------	------------------	----------------------	------