



FEATURES

- 700 MHz to 40 GHz
- Compensation for Temperature Drift
- Input Regulators for Improved Stability
 - Versus Power Supply Variations
- 0 to 10 Volt Tuning
- 0° C to +65° C Temperature Range



DESCRIPTION

MICRO LAMBDA YIG Oscillators, model type **MLOS, MLXS, MLOB and MLXB-Series** are available with integrated analog driver circuits.

MICRO LAMBDA drivers eliminate the need for customers to design or develop their own driver circuits and sophisticated test and alignment procedures. Integrating a driver at MICRO LAMBDA's factory ensures that peak performance will be achieved at the time of manufacture. Alignment and compensation with the particular YIG oscillator can be maximized down to the component level.

All drivers in this series provide input voltage regulators, and compensation circuits to improve frequency drift.

COMMERCIAL POSITIVE INPUT ANALOG DRIVER SELECTION GUIDE: PA SERIES

YIG TUNED OSCILLATORS WITH ANALOG DRIVERS

DRIVER INPUT & RESPONSE	SPECIFICATION (0 to + 65 deg. C)
Tuning Command	0 Volts = Lowest Frequency 10 Volts = Highest Frequency
Tuning Accuracy (excluding hysteresis)	See Table
Tuning Speed	2 mSec for 1 GHz step to within +/-10 MHz. Residual FM = 50-100 kHz Pk-Pk
Sweep Speed (0 - 10 Volt Ramp)	25 mSec Up / 10 mSec Retrace for 1 GHz, Linearity = 0.1 % Residual FM = 50-100 kHz Pk-Pk
Main Driver Inputs	
Supply Voltage & Current	+15 V +/- .5 V @ Bias Current + Tuning Current + 50 mA, Max. -15 V +/- .5 V @ 50 mA, (Plus Oscillator -5 Vdc Current if any) Max.
Supply Voltage Pushing	+/- 0.2 MHz Max. @ +/- .5 Vdc
Supply Voltage Ripple	10 mV Ripple Pk-Pk from 2 kHz to 3 MHz
Ground	Chassis Ground
Tuning Input Resistance	> 10 kOhms
Common Mode Rejection	> 40 dB
Heater Voltage Inputs	24 Vdc +/- 4 Vdc @ 300 mA Surge for 2 Sec., 25 mA Steady State Polarity Independent: ±12 Vdc or ±15 Vdc acceptable
FM Coil Driver Option ("PF" Option)	
Voltage Input	+/- 10 Vdc
Input Impedance	1 kOhms
Sensitivity (Note 1)	+/- 2.5 MHz
Frequency Deviation	+/- 25 MHz
Current Requirements (Max. +/- Deviation)	+/- 100 mA

Note 1: Sensitivity Adjustment Available. Sensitivity Stated is Average Over Frequency Range.

PA SERIES – CONTINUED

1.25" YIG Oscillators with Positive Input Analog Drivers (0° C to +65° C)

Model Number	Frequency GHz	Accuracy (MHz) *	Current +15 V (mA)	Current -15 V (mA)	Outline Drawing	Outline Drawing (PF-Option)
Octave Bands						
MLOB-0102PA	1-2	+/- 3	200	50	11-024	11-025
MLOB-0204PA	2-4	+/- 6	300	50	11-024	11-025
MLOB-0408PA	4-8	+/- 8	550	50	11-024	11-025
MLOB-0812PA	8-12.4	+/- 12	780	50	11-024	11-025
MLOB-1218PA	12-18	+/- 14	1050	50	11-024	11-025
Multi-Octave Bands						
MLOB-0702PA	.7-2	+/- 6	250	50	11-024	11-025
MLOB-0704PA	.7-4	+/- 8	350	50	11-024	11-025
MLOB-0208PA	2-8	+/- 12	550	50	11-024	11-025
MLOB-0306PA	3-6	+/- 6	450	50	11-024	11-025
MLOB-0212PA	2-12	+/- 15	730	100	11-024	11-025
MLOB-0310PA	3.5-10.5	+/- 15	675	100	11-024	11-025
MLOB-0412PA	4-12.4	+/- 15	780	100	11-024	11-025
MLOB-0716PA	7-16	+/- 18	900	50	11-024	11-025
MLXB-0618PA	6-18	+/- 25	1050	100	11-024	11-025
MLOB-0820PA	8-20	+/- 30	1175	50	11-024	11-025

* Accuracy includes frequency drift and linearity errors over the temperature range.

Cylindrical YIG Oscillators with Positive Input Analog Drivers (0° C to +65° C)

Model Number	Frequency GHz	Accuracy (MHz) *	Current +15 V (mA)	Current -15 V (mA)	Outline Drawing	Outline Drawing (PF-Option)
Octave Bands						
MLOS-0102PA	1-2	+/- 3	200	50	11-016	**
MLOS-0204PA	2-4	+/- 6	300	50	11-016	**
MLOS-0408PA	4.0-8.0	+/- 8	550	50	11-016	**
MLOS-0812PA	8.0-12.4	+/- 12	780	50	11-013	11-026
MLOS-1218PA	12.0-18.0	+/- 14	1050	50	11-013	11-026
Multi-Octave Bands						
MLOS-0702PA	.7-2	+/- 6	250	50	11-016	**
MLOS-0704PA	.7-4	+/- 8	350	50	11-016	**
MLOS-0208PA	2-8	+/- 12	550	50	11-016	**
MLOS-0306PA	3-6	+/- 6	450	50	11-016	**
MLOS-0310PA	3.5-10.5	+/- 15	675	100	11-016	**
MLOS-0412PA	4-12.4	+/- 15	780	100	11-016	**
MLOS-0716PA	7-16	+/- 15	900	50	11-013	11-026
MLXS-0618PA	6-18	+/- 25	1050	100	11-013	11-026
MLOS-0820PA	8-20	+/- 30	1175	50	11-013	11-026
MLXS-0218PA	2-18	+/- 35	1150	100	11-013	11-026
MLXS-0220PA	2-20	+/- 35	1175	100	11-013	11-026
Millimeter Wave Bands						
MLOS-1826PA	18-26.5	+/- 30	1200	50	11-015	11-109
MLOS-1724PA	17-24	+/- 30	1100	50	11-015	11-109
MLOS-1840PA	18-40	+/- 40	1200	50	11-015	11-109
MLOS-2040PA	20-40	+/- 40	1200	50	11-015	11-109
MLOS-2640PA	26-40	+/- 40	1200	50	11-015	11-109

* Accuracy includes frequency drift and linearity errors over the temperature range.

** Outline Drawing Available from Factory or Web-site.

Outline Drawing: 11-013, 015 & 016

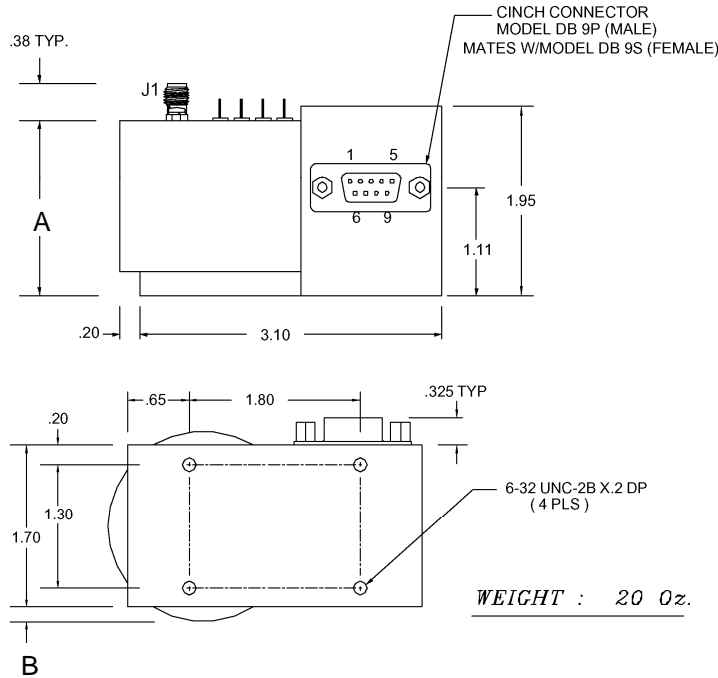

Case	A	B	Weight
11-013	1.65	.025	18 oz.
11-015	1.80	.15	20 oz.
11-016	1.42	.025	17 oz.

Connector	Functions
1	Driver Control
2	Control Return
3	GND
4	- Supplies Voltage
5	+ Supplies Voltage
6	20-30 V Heater Supply
7	Heater Return
8	+ FM
9	- FM
J1	RF Output

NOTES :

1. - DIMENSIONS ARE IN INCHES
2. - SUPPLY & GROUND WIRES = 20-22 GAUGE
ALL OTHER WIRES = 24-26 GAUGE
3. - THERMAL COMPOUND REQUIRED BETWEEN
BASE PLATE AND MOUNTING SURFACE
4. - DRIVER CONTROL: 0V = Fmin ; 10V = Fmax

Outline Drawing: 11-024, 11-025

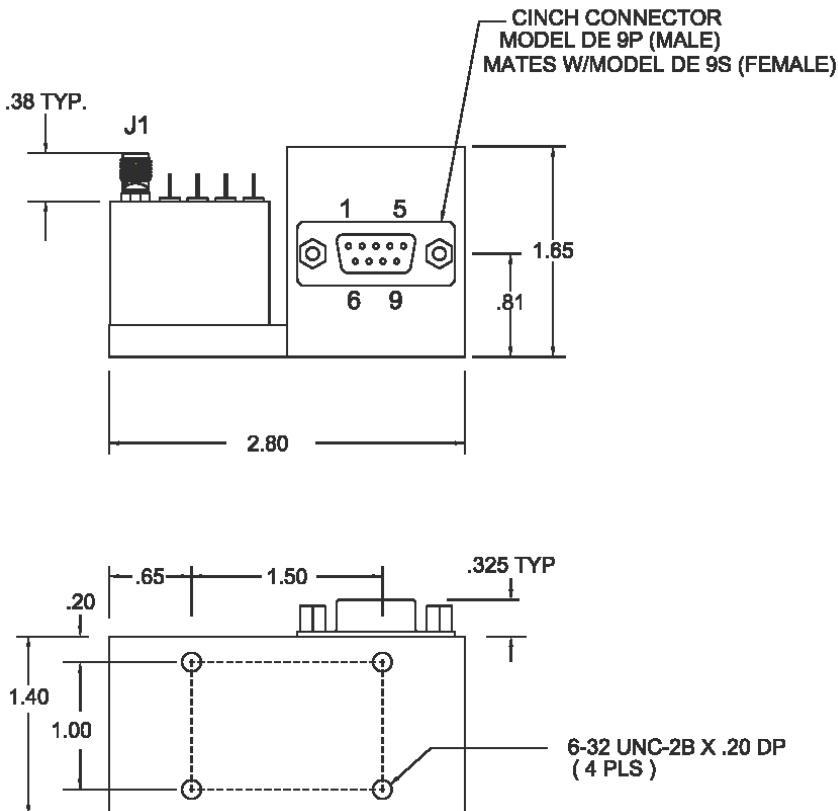

Connector for 11-024

Connector	Functions
1	Driver Control
2	Control Return
3	GND
4	- Supplies Voltage
5	+ Supplies Voltage
6	20-30 V Heater Supply
7	Heater Return
8	+ FM
9	- FM
J1	RF Output

Connector for 11-025

CONN	FUNCTIONS
1	DRIVER CONTROL
2	CONTROL RETURN
3	GND
4	- SUPPLIES VOLTAGE
5	+ SUPPLIES VOLTAGE
6	20-30 V HTR SUPPLY
7	HEATER RETURN
8	FM ± 10V
9	FM GROUND
J1	RF OUTPUT

Outline Drawing: 11-026

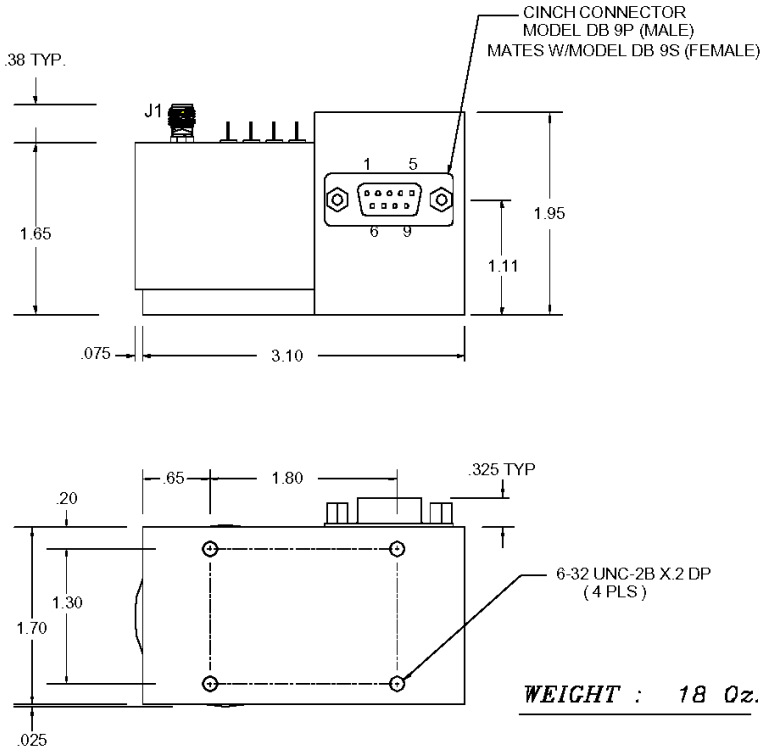

CONN	FUNCTIONS
1	DRIVER CONTROL
2	COMMON GROUND
3	GND
4	- SUPPLY VOLTAGE
5	+ SUPPLY VOLTAGE
6	20-30 V HTR SUPPLY
7	HEATER RETURN
8	FM (±10V)
9	FM RETURN (GRD)
J1	RF OUTPUT

NOTES :

1. - DIMENSIONS ARE IN INCHES
2. - SUPPLY & GROUND WIRES = 20-22 GAUGE
ALL OTHER WIRES = 24-26 GAUGE
3. - THERMAL COMPOUND REQUIRED BETWEEN
BASE PLATE AND MOUNTING SURFACE
4. - DRIVER CONTROL: 0V = Fmin ; 10V = Fmax

Outline Drawing: 11-109

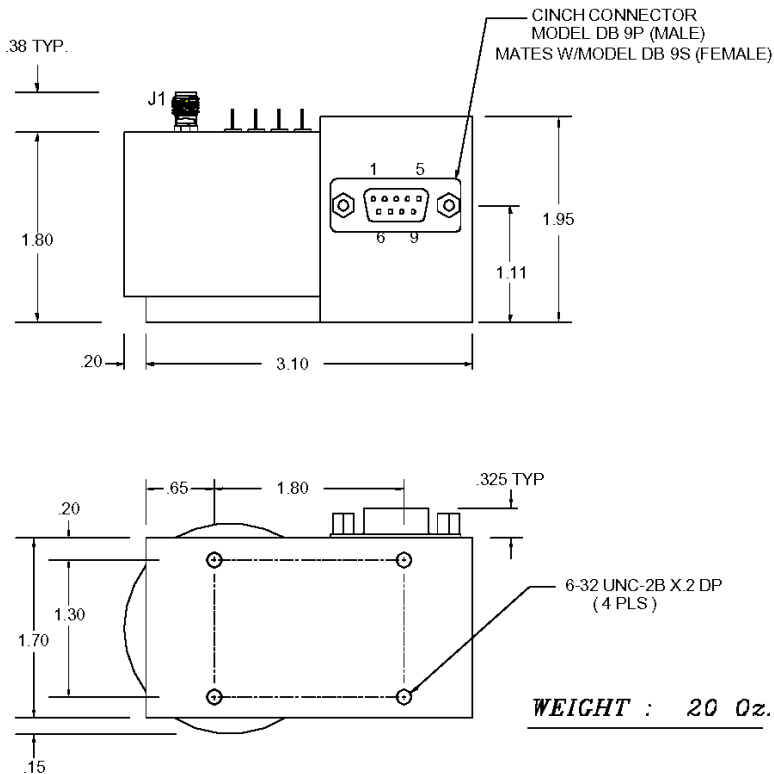

CONN	FUNCTIONS
1	DRIVER CONTROL
2	COMMON GROUND
3	GND
4	- SUPPLY VOLTAGE
5	+ SUPPLY VOLTAGE
6	20-30 V HTR SUPPLY
7	HEATER RETURN
8	FM (±10V)
9	FM RETURN (GRD)
J1	RF OUTPUT

NOTES :

1. - DIMENSIONS ARE IN INCHES
2. - SUPPLY & GROUND WIRES = 20-22 GAUGE
ALL OTHER WIRES = 24-26 GAUGE
3. - THERMAL COMPOUND REQUIRED BETWEEN
BASE PLATE AND MOUNTING SURFACE
4. - DRIVER CONTROL: 0V = Fmin ; 10V = Fmax