

## FEATURES

- Superior Phase Noise
- 1 kHz Step Size
- External Reference 1-200 MHz (Optional)
- PXI, Compact PCI Size Compatible
- 5 Line Serial & USB Control

## DESCRIPTION

The **MLSP-Series** of YIG-Based synthesizers are ideal as the main local oscillators in receiving systems, frequency converters and test and measurement equipment. They provide 1 kHz frequency resolution over the 600 MHz to 20 GHz frequency range. Power levels of +10 to +15 dBm are provided through out the series and full band tuning speed is 5 mSec. The units are 5" x 3" x 1" high and fit a 2 slot PXI chassis.

## APPLICATIONS

Test Equipment  
Local Oscillators  
Frequency Converters

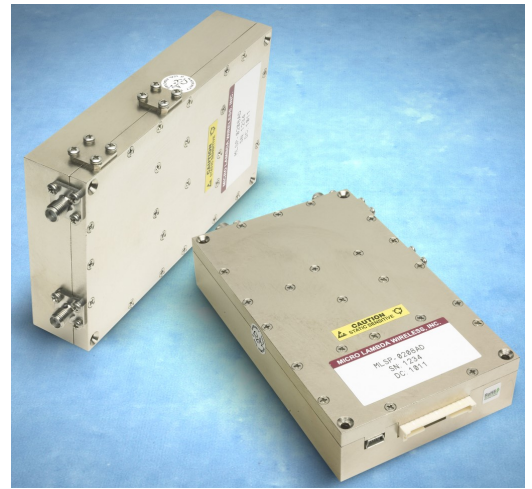

## PERFORMANCE SPECIFICATIONS

(Operating Case Temperature: 0° to +60° C Baseplate) (Note 1)

Model No.	MLSP-0625	MLSP-2080	MLSP-4016	MLSP-6018	MLSP-8020
<b>RF Specifications</b>					
Output Frequency (Note 2 & 10)	0.6-2.5 GHz	2-8 GHz	4-16 GHz	6-18 GHz	8-20 GHz
Output Power Min. (Note 8 & 10 )	+13 dBm	+15 dBm	+12 dBm	+12 dBm	+10 dBm
Po Variation over Freq/Temp	4 dB	4 dB	5 dB	6 dB	6 dB
Step Size, Min.	1 kHz	1 kHz	1 kHz	1 kHz	1 kHz
Switching Speed, 100 MHz Step, Typ.	1 mS	1 mS	1 mS	1 mS	1 mS
1000 MHz Step, Typ.	3 mS	3 mS	3 mS	3 mS	3 mS
Full Band Step, Typ.	5 mS	5 mS	5 mS	6 mS	6 mS
Warm-up Time ("Lock") @ 0C (Minutes) (with Internal Crystal Reference)	3.0	3.0	3.0	3.0	3.0
Output Impedance	50 Ohms	50 Ohms	50 Ohms	50 Ohms	50 Ohms
Load VSWR	2.0:1	2.0:1	2.0:1	2.0:1	2.0:1
Harmonics	-8 dBc	-12 dBc	-12 dBc	-12 dBc	-12 dBc
Non-Harmonic Spurious	-60 dBc	-60 dBc	-60 dBc	-60 dBc	-60 dBc
<b>Phase Noise Performance</b>					
(with Internal Crystal Reference)					
@ 100 Hz Offset	86 dBc/Hz	80 dBc/Hz	75 dBc/Hz	72 dBc/Hz	70 dBc/Hz
@ 1 kHz Offset	101 dBc/Hz	95 dBc/Hz	90 dBc/Hz	89 dBc/Hz	87 dBc/Hz
@ 10 kHz Offset	98 dBc/Hz	97 dBc/Hz	88 dBc/Hz	90 dBc/Hz	88 dBc/Hz
@ 100 kHz Offset	117 dBc/Hz	117 dBc/Hz	115 dBc/Hz	115 dBc/Hz	118 dBc/Hz
@ 1 MHz Offset	142 dBc/Hz	142 dBc/Hz	138 dBc/Hz	138 dBc/Hz	138 dBc/Hz
@ 10 MHz Offset	157 dBc/Hz	155 dBc/Hz	155 dBc/Hz	154 dBc/Hz	153 dBc/Hz
@ 100 MHz Offset	170 dBc/Hz	168 dBc/Hz	168 dBc/Hz	166 dBc/Hz	163 dBc/Hz

## MLSP PERFORMANCE SPECIFICATIONS (Continued)

Model No.	MLSP-0625	MLSP-2080	MLSP-4016	MLSP-6018	MLSP-8020
<b>Reference Oscillator Options</b>					
<b>Option A</b>					
External Reference (Note 3)	50 - 200 MHz	50 - 200 MHz	50 - 200 MHz	50 - 200 MHz	50 - 200 MHz
External Ref. Input Power	0 +/- 3 dBm	0 +/- 3 dBm	0 +/- 3 dBm	0 +/- 3 dBm	0 +/- 3 dBm
Frequency Stability (<+/- 20ppm)	Cust Supplied	Cust Supplied	Cust Supplied	Cust Supplied	Cust Supplied
<b>Option B</b>					
External Reference with Internal Crystal (Note 4)	10 - 100 MHz	10 - 100 MHz	10 - 100 MHz	10 - 100 MHz	10 - 100 MHz
External Ref. Input Power	0 +/- 3 dBm	0 +/- 3 dBm	0 +/- 3 dBm	0 +/- 3 dBm	0 +/- 3 dBm
Frequency Stability (Note 9)	Cust Supplied	Cust Supplied	Cust Supplied	Cust Supplied	Cust Supplied
<b>Option C</b>					
Internal Reference	100 MHz	100 MHz	100 MHz	100 MHz	100 MHz
Frequency Stability	+/- 1 PPM	+/- 1 PPM	+/- 1 PPM	+/- 1 PPM	+/- 1 PPM
<b>Supply Voltage &amp; Current (Note 5)</b>					
+15 Vdc ( $\pm 0.5$ ) Vdc)	525 mA	825 mA	1550 mA	1650 mA	1800 mA
+5 Vdc ( $\pm 0.25$ ) Vdc)	300 mA	300 mA	325 mA	325 mA	325 mA
Power dissipation	9.4 watts	13.9 watts	25 watts	27 watts	29 watts
<b>Supply Voltage Ripple</b> (Pk-Pk from 60 Hz to 3 MHz)	<50 mV	<50 mV	<50 mV	<50 mV	<50 mV
<b>Control Format</b>	5-Line Serial USB	5-Line Serial USB	5-Line Serial USB	5-Line Serial USB	5-Line Serial USB
<b>Phase Lock Alarm (P13) (TTL)</b>	1=Locked	1=Locked	1=Locked	1=Locked	1=Locked
<b>Weight</b>	15 oz / 426 g	15 oz / 426 g	15 oz / 426 g	15 oz / 426 g	15 oz / 426 g

### MLSP Options:

**Option A:** External Reference / No Internal Reference

**Option B:** Internal Reference / External Reference

**Option C:** Internal Reference / No External Reference, Drawing 181-003 & 181-004

**Option D:** RF Connectors Front, Drawing 181-001

**Option E:** RF Connectors Side, Drawing 181-002

**Option G:** RF Power Leveling (-20dB Delta from attained power level (i.e. +10 to -10 dBm), in 0.1dB increments). Degrades max RF output power by 4-6 dB when implemented. Changes RF Phase up to 160° versus frequency and attenuation. (Note 10)

**Option J:** Internal Reference with Reference Output (100 MHz @ 0 dB  $\pm$  3 dB,  $\pm$  1 PPM), Drawing 181-005 & 181-006

Part Number Example: MLSP-8020CE is an 8 GHz to 20 GHz with Internal Reference and RF connectors on side.

#### Notes:

- 1) Special operating temperature range available.
- 2) Special frequency ranges available.
- 3) 50-100 MHz OCXO recommended for best phase noise performance. External reference directly effects phase noise performance.
- 4) Output phase noise performance is not dependent on external reference phase noise.
- 5) All values stated for units with external reference. For internal reference add 125mA on the +15 Vdc line.
- 8) RF Power level control, adjustable over a 20 dB range in 0.1 dB increments (Option G). Level flatness specified @ 25 °C  $\pm$  10 °C.
- 9) Frequency accuracy must be within exact reference frequency selected, +/- 5ppm.
- 10) RF Power Leveling is available for models 10 GHz and below.

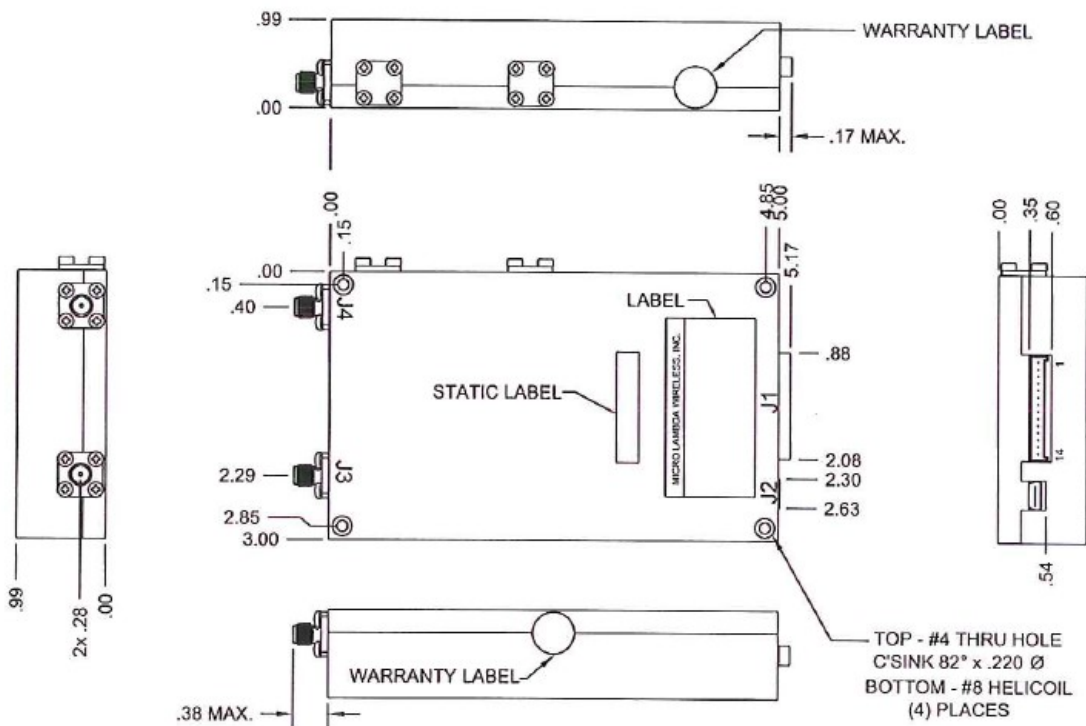

**NOTES :**

- J1 MALE: - MOLEX# 35363-1460
- J1 MATES WITH: - MOLEX# 35507-1400
- CRIMP PIN: - MOLEX# 50212-8000

- J1 POWER SUPPLY INPUTS REQUIRED FOR USB OPERATION
- J1 RECOMMENDED WIRE SIZE = A.W.G. 22-24
- (\* ) ACTIVE LOW

CONNECTIONS			
CONN.	TYPE	PIN #	FUNCTION
J1	35363-1460	1	+15 VDC, +12V OPT.
J1	35363-1460	2	+15 VDC, +12V OPT.
J1	35363-1460	3	GROUND
J1	35363-1460	4	GROUND
J1	35363-1460	5	+ 5 VDC
J1	35363-1460	6	+ 5 VDC
J1	35363-1460	7	N/C
J1	35363-1460	8	N/C
J1	35363-1460	9	CLOCK
J1	35363-1460	10	DATA IN
J1	35363-1460	11	SELECT (*)
J1	35363-1460	12	BUSY
J1	35363-1460	13	LOCK ALARM
J1	35363-1460	14	DATA OUT

CONNECTIONS			
CONN.	TYPE	PIN #	FUNCTION
J2	USB MINI-B	1	+V
J2	USB MINI-B	2	D-
J2	USB MINI-B	3	D+
J2	USB MINI-B	4	GND
J2	USB MINI-B	5	GND
J3	SMA-FEMALE	1	REF. INPUT
J4	SMA-FEMALE	1	RF OUTPUT

UNLESS OTHERWISE SPECIFIED DIMENSIONS ARE IN INCHES TOLERANCE ARE:

FRACTIONS DECIMALS ANGLES  
 . . . . .  
 . . . . .  
 . . . . .

WEIGHT 15 Oz. / 425gr

FINISH

DO NOT SCALE DRAWING

CONTRACT NO.

APPROVALS DATE

DRAWN N.NGUYEN 3/12/12

ENGR DS 3/12/12

MANUF.

Q.A.



**MICRO LAMBDA WIRELESS, INC.**

**MLSP SYNTHESIZER, EXT. REF. ( FRONT )**

SIZE	CAGE NO <b>ORN63</b>	DWG. NO <b>181 - 001</b>	REV. <b>B</b>
------	-------------------------	-----------------------------	------------------

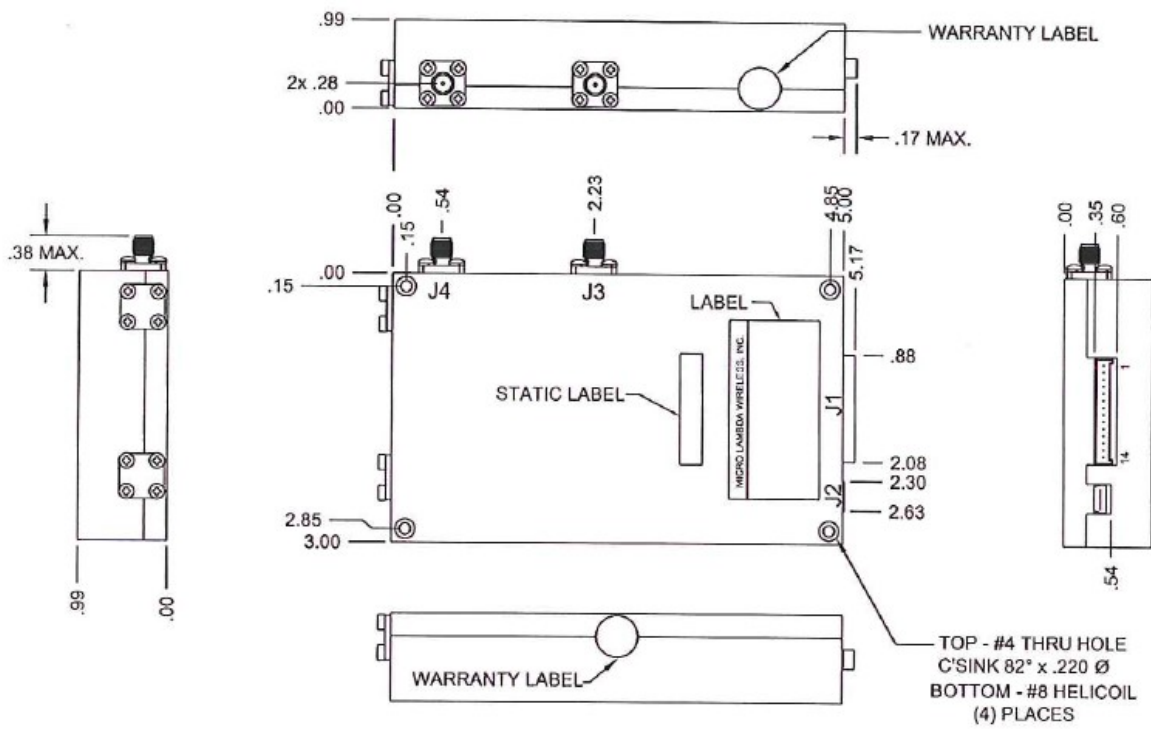

**NOTES :**

- J1 MALE: - MOLEX# 35363-1460
- J1 MATES WITH: - MOLEX# 35507-1400
- CRIMP PIN: - MOLEX# 50212-8000
- J1 POWER SUPPLY INPUTS REQUIRED FOR USB OPERATION
- J1 RECOMMENDED WIRE SIZE = A.W.G. 22-24
- (\*) ACTIVE LOW

CONNECTIONS			
CONN.	TYPE	PIN #	FUNCTION
J1	35363-1460	1	+15 VDC, +12V OPT.
J1	35363-1460	2	+15 VDC, +12V OPT.
J1	35363-1460	3	GROUND
J1	35363-1460	4	GROUND
J1	35363-1460	5	+ 5 VDC
J1	35363-1460	6	+ 5 VDC
J1	35363-1460	7	N/C
J1	35363-1460	8	N/C
J1	35363-1460	9	CLOCK
J1	35363-1460	10	DATA IN
J1	35363-1460	11	SELECT (*)
J1	35363-1460	12	BUSY
J1	35363-1460	13	LOCK ALARM
J1	35363-1460	14	DATA OUT

CONNECTIONS			
CONN.	TYPE	PIN #	FUNCTION
J2	USB MINI-B	1	+V
J2	USB MINI-B	2	D-
J2	USB MINI-B	3	D+
J2	USB MINI-B	4	GND
J2	USB MINI-B	5	GND
J3	SMA-FEMALE	1	REF. INPUT
J4	SMA-FEMALE	1	RF OUTPUT

UNLESS OTHERWISE SPECIFIED DIMENSIONS ARE IN INCHES TOLERANCE ARE		CONTRACT NO.	
FRACTIONS	DECIMALS	APPROVALS	DATE
•	.XX		
•	.XXX		
•	.010		
WEIGHT	15 Oz. / 425gr	DRAWN	N.NGUYEN 3/12/12
FINISH		ENGR.	DS 3/12/12
		MANUF.	
		QA	
DO NOT SCALE DRAWING			

**MICRO LAMBDA WIRELESS, INC.**

*MLSP SYNTHESIZER, EXT. REF. ( SIDE )*

SIZE	CASE No	DWG. No.	REV.
	0RN63	181 - 002	B